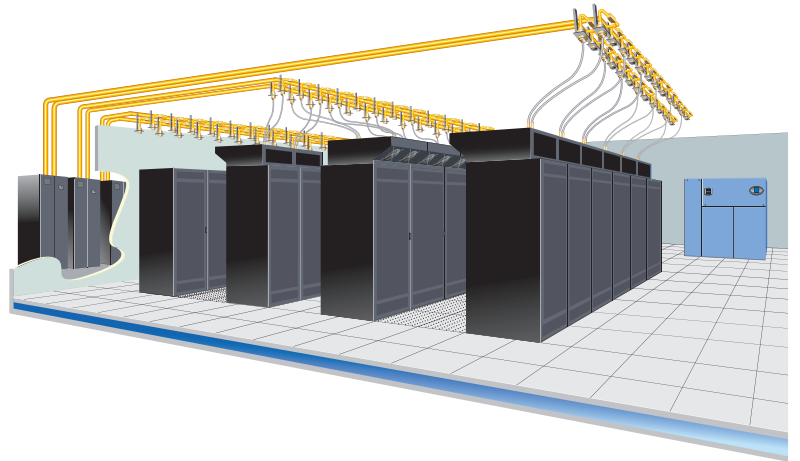


# Liebert XDV™

User Manual—50 & 60 Hz



## GENERAL SAFETY GUIDELINES

### SAVE THESE INSTRUCTIONS



#### WARNING

Risk of electric shock. Can cause injury or death.

Disconnect local and remote power supplies before working within.

Before proceeding with installation of XD cooling unit's, read all instructions, verify that all the parts are included, and check the nameplate to be sure the XD cooling unit's voltage matches available utility power.

Follow all local codes.



#### WARNING

Risk of unit falling over when installed on top of cabinet. Can cause property damage, injury or death.

The XDV is top-heavy. Use extreme caution and care when moving and installing this unit.



#### WARNING

Risk of explosive discharge. Can cause equipment damage, injury or death.

Closing service valves may isolate liquid refrigerant, causing high pressure and rupture of piping. Do not close valves without follow recommended procedures for repair, maintenance and replacement of components. Installing pressure relief valves in field piping that may become isolated by service valves.



#### NOTE

*This document must be used together with site specific documentation and documentation for other parts of the system (heat rejection devices and cooling modules).*



#### NOTE

*Before any action that could cause a disturbance in the Liebert XD system's cooling function is begun, the facility manager **MUST** be informed. In addition, after the action is taken and the work is finished, the facility manager **MUST** be informed.*

### Fluorinated Greenhouse Gas Requirements—European Union

Stationary air conditioning, refrigeration, heat pump equipments and stationary fire protection systems in the European Community market and operating with fluorinated greenhouse gases (f-gas), such as R407C, R134a, R410A, must comply with the F-Gas Regulation: (EC) No. 842/2006 (F-gas). The regulation prohibits, among other actions, venting fluorinated greenhouse gases to the atmosphere.

The F-Gas Regulation also requires operators to use all measures that are technically feasible and do not entail disproportionate cost to prevent leakage of these gases, to test for leakage regularly and to recover f-gas during equipment service and maintenance and before disposing of equipment.

Refer to the full regulation for additional details.

---

# TABLE OF CONTENTS

<b>GENERAL SAFETY GUIDELINES</b> .....	<b>INSIDE FRONT COVER</b>
<b>1.0 LIEBERT XDV COMPONENT LOCATIONS AND MODEL NUMBER NOMENCLATURE</b> .....	<b>1</b>
<b>2.0 INSTALLATION</b> .....	<b>2</b>
2.1 References .....	2
2.2 Pre-Installation Checks .....	2
2.3 Parts Included With Liebert XDV .....	2
2.4 Installation Considerations .....	2
2.4.1 Room Preparation .....	2
<b>3.0 GENERAL PRODUCT INFORMATION</b> .....	<b>3</b>
3.1 Product/System Description .....	3
3.2 Checking and Unpacking .....	3
3.3 Equipment Inspection .....	4
3.3.1 Recyclable Packaging .....	4
3.3.2 Unit Handling .....	5
3.3.3 Unpacking the Unit .....	5
<b>4.0 MECHANICAL CONSIDERATIONS</b> .....	<b>8</b>
4.1 Determining Placement in the Conditioned Space .....	8
4.2 Changing the Air Intake Location .....	9
<b>5.0 MOUNTING THE LIEBERT XDV</b> .....	<b>10</b>
5.1 Mounting the Liebert XDV on Top of the Cabinet .....	10
5.1.1 Bolting Liebert XDV to Top of Cabinet .....	10
5.1.2 Using Supplied Clips for Mounting .....	12
5.2 Suspended Mounting Method .....	13
5.2.1 Suspending the Liebert XDV from Unistruts .....	14
5.2.2 Suspending the Liebert XDV from Overhead Structures .....	14
5.3 Mounting Liebert XDV's in Stacked Setup .....	16
5.3.1 Hanging Stacked Liebert XDV's from Unistruts .....	17
5.3.2 Hanging Stacked Liebert XDV's from the Overhead Structure .....	18
<b>6.0 PIPING</b> .....	<b>19</b>
6.1 European Union Fluorinated Greenhouse Gas Requirements .....	19
6.2 System Connection Configuration .....	19
6.2.1 Piping Connections to Liebert XDP or Liebert XDC .....	20
6.3 Connection Methods and Points .....	20
6.4 Hard Piped Connection Sizes .....	22
6.4.1 Holding Charge—Hard-Piped Units .....	22
6.4.2 Brazing Preparations—Hard-Piped Units .....	23
6.5 Recommended Piping Size .....	23
6.6 Connection Methods—One-Shot Connections .....	24
6.6.1 Refrigerant Charge—Pre-Charged Option .....	25
6.7 Field Installation of Liebert Flex Pipe Kit on Liebert XDV .....	25

---

6.8	Connecting Liebert XD Flex Pipe to Liebert XDV Modules . . . . .	25
6.9	Connecting a Liebert XDV with Liebert Flex Pipe to an Operational Liebert XD System . . . . .	26
6.10	Disconnecting a Liebert XDV With Liebert Flex Pipe From a Liebert XD System . . . . .	28
6.11	Insulation . . . . .	29
<b>7.0</b>	<b>ELECTRICAL . . . . .</b>	<b>30</b>
7.1	Connecting High Voltage Cables for CSA/C-US Certified Units . . . . .	30
7.2	Connecting Low Voltage Wiring—Optional . . . . .	32
<b>8.0</b>	<b>INSTALLATION CHECKLIST AND SYSTEM FILL FOR STARTUP . . . . .</b>	<b>33</b>
8.1	Checklist for Proper Installation . . . . .	33
8.2	Charging with Refrigerant and Starting the Liebert XD System . . . . .	33
<b>9.0</b>	<b>OPERATION . . . . .</b>	<b>34</b>
9.1	Start the Liebert XDV . . . . .	34
<b>10.0</b>	<b>MAINTENANCE . . . . .</b>	<b>35</b>
10.1	Fluorinated Greenhouse Gas Requirements . . . . .	35
10.2	Internal Access . . . . .	35
	10.2.1 Accessing Internal Electrical Components . . . . .	36
<b>11.0</b>	<b>SPECIFICATIONS . . . . .</b>	<b>38</b>

---

## FIGURES

Figure 1	Liebert XDV component locations . . . . .	1
Figure 2	Liebert XDV model number nomenclature . . . . .	1
Figure 3	Liebert XDV hydraulic diagram . . . . .	3
Figure 4	Recommended unit handling equipment . . . . .	4
Figure 5	Removing domestic shipping package . . . . .	5
Figure 6	Removing export shipping package . . . . .	6
Figure 7	Removing Liebert XDV from shipping pallet . . . . .	7
Figure 8	Liebert XDV dimensions . . . . .	8
Figure 9	Changing the Liebert XDV's air intake location . . . . .	9
Figure 10	Positioning the Liebert XDV . . . . .	10
Figure 11	Mounting hole locations—standard mounting method . . . . .	11
Figure 12	Mounting hole locations—alternate mounting points . . . . .	11
Figure 13	Mounting clip placement . . . . .	12
Figure 14	Dimensions—optional external hanging brackets . . . . .	13
Figure 15	Suspending Liebert XDV from Unistruts . . . . .	14
Figure 16	Suspending Liebert XDV from the overhead structure . . . . .	15
Figure 17	Stacking configuration offset . . . . .	16
Figure 18	Attach hanger brackets to Liebert XDV for stacked arrangement . . . . .	17
Figure 19	Stacked Liebert X DVs suspended from Unistruts . . . . .	17
Figure 20	Stacked Liebert X DVs ready for suspension from overhead structure . . . . .	18
Figure 21	Typical Liebert XDV piping—interlaced connections . . . . .	19
Figure 22	Typical Liebert XDV piping—non-interlaced connection . . . . .	20
Figure 23	Hard-piped connection diagram . . . . .	21
Figure 24	Piping location and connection sizes—hard-piped units . . . . .	22
Figure 25	Schrader valve location for venting holding charge . . . . .	23
Figure 26	Piping location and connection sizes—pre-charged units with one-shot connections . . . . .	24
Figure 27	Liebert XD Flex Pipe dimensions—straight and 90-degree connections . . . . .	25
Figure 28	Liebert XD prefabricated piping assembly . . . . .	26
Figure 29	Detail view of Liebert XD Flex Pipe and prefabricated piping port . . . . .	27
Figure 30	Liebert XD system with prefabricated piping assembly and Liebert XD Flex Pipe . . . . .	27
Figure 31	Profile view of the Liebert XD system with one-shot connections . . . . .	28
Figure 32	Piping mains without Liebert XDV and Liebert Flex Pipe . . . . .	29
Figure 33	Liebert XDV electrical connections for CSA-approved units . . . . .	30
Figure 34	Liebert XDV electrical connections for CE-approved units . . . . .	31
Figure 35	Low voltage connections . . . . .	32
Figure 36	Fan switches . . . . .	34
Figure 37	Accessing internal electrical components . . . . .	36
Figure 38	Removing the fan tray . . . . .	37

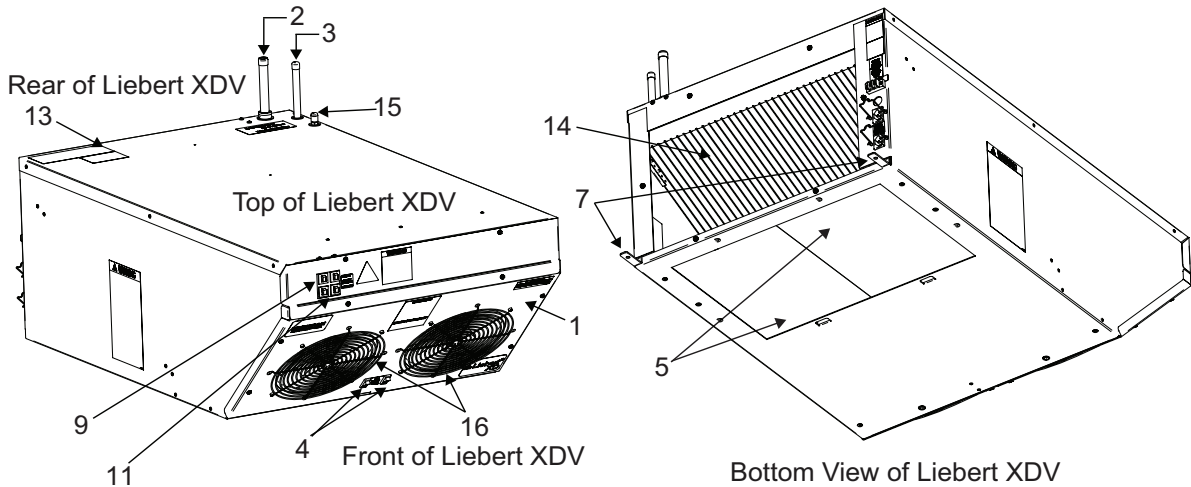
## TABLES

Table 1	Application limits . . . . .	2
Table 2	Dimensional data . . . . .	8
Table 3	Suspension hardware and bracket dimensional data . . . . .	13
Table 4	Branch piping sizes for refrigerant loop . . . . .	24
Table 5	Liebert XDV10 specifications . . . . .	38
Table 6	Liebert XDV8 specifications . . . . .	39
Table 7	Liebert XD Liebert Flex Pipe assemblies, supply and return . . . . .	40

---

# 1.0 LIEBERT XDV COMPONENT LOCATIONS AND MODEL NUMBER NOMENCLATURE

Figure 1 Liebert XDV component locations



## XDV Components and Nomenclature

1. Removable Fan Tray
2. Return Line
3. Supply Line
4. Fan Switches
5. Removable Blocker Plates
6. Removable Rear Inlet Grille
7. Mounting Clips for Cabinets
8. Primary Power Inlet (CE-approved units have non-detachable power cord)
9. Primary Circuit Breaker
10. Secondary Power Inlet (CE-approved units have non-detachable power cord)
11. Secondary Circuit Breaker
12. Connections for Condensate Detection Option
13. Serial Tag
14. Heat Exchanger
15. Schrader Valve
16. Fans

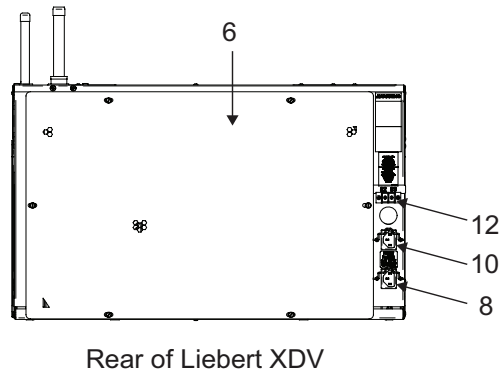
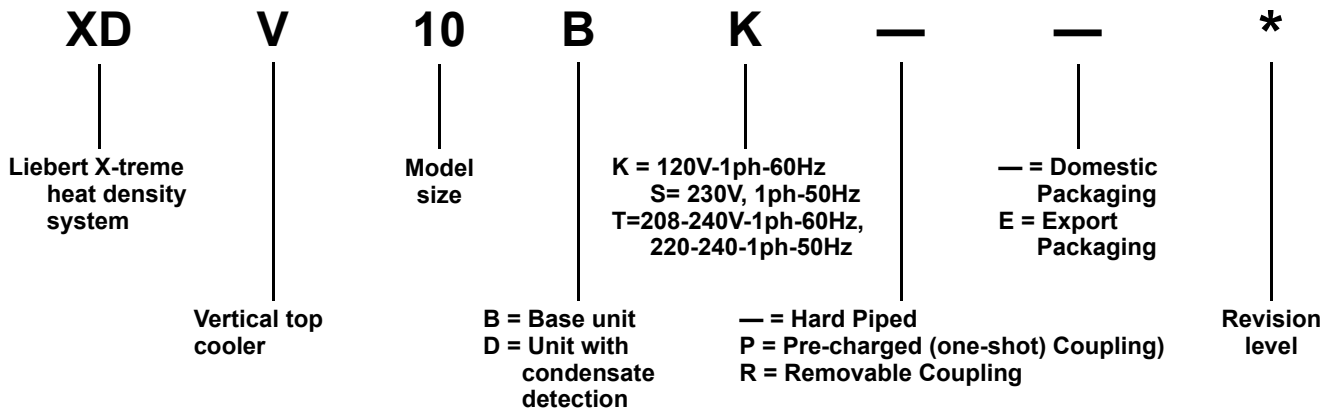


Figure 2 Liebert XDV model number nomenclature

Example: XDV10BK--\*



## 2.0 INSTALLATION

### 2.1 References

This document must be used together with site specific documentation and documentation for other parts of the system.

### 2.2 Pre-Installation Checks

- Verify that the Liebert XDV voltage matches the available utility power. The serial tag with this information is on the top of the unit, near the rear.
- Check the received materials to be sure all required assemblies and parts have been received. If you discover any external damage, report it to the shipping company and your local Liebert representative.

### 2.3 Parts Included With Liebert XDV

- Installation manual (this document)
- Liebert XDV module
- Parts bag including
  - IEC 10 ft. (3m) power cords, 2 (60Hz only; power cords for 50Hz are attached)
  - 1/4 - 20 full thread 1" bolts, 4
  - 1/4 inch locking hex nuts, 2
  - mounting clips, 2

### 2.4 Installation Considerations

Each Liebert XDV module is to be securely mounted either on the top of a computer cabinet or rack or above the heat-producing equipment. Mounting the Liebert XDV above the rack requires Liebert's optional mounting kit.

The units are designed to be mounted without modification on Liebert Foundation™ cabinets. Mounting clips included with the Liebert XDV permit installation on other manufacturers' cabinets and racks. The clips also can be used with the Foundation for stronger attachment.

Determine whether the Liebert XDV includes the condensate detection option (factory-installed). This option will require separate low voltage connections to a monitoring unit.

To minimize the possibility of condensation, insulate all piping between the Liebert XDV and the Liebert XDP or Liebert XDC.

**Table 1 Application limits**

Input Voltage		Range of Return Air Conditions to Unit	
Minimum	Maximum	Dry Bulb Temp.	Relative Humidity
-10%	+10%	60° to 100°F (16° to 38°C)	20% to 80%

#### 2.4.1 Room Preparation

The room should be well insulated and must have a sealed vapor barrier. The vapor barrier in the ceiling and walls can be a polyethylene film. Paint on concrete walls and floors should contain either rubber or plastic.



#### NOTE

*The vapor barrier is the single most important requirement for maintaining environmental control in the conditioned space.*

Outside or fresh air should be kept to a minimum when temperature and humidity must be tightly controlled. Outside air adds to the cooling, heating, dehumidifying and humidifying loads of the site. Doors should be properly sealed to minimize leaks and should not contain ventilation grilles.



## 3.0 GENERAL PRODUCT INFORMATION

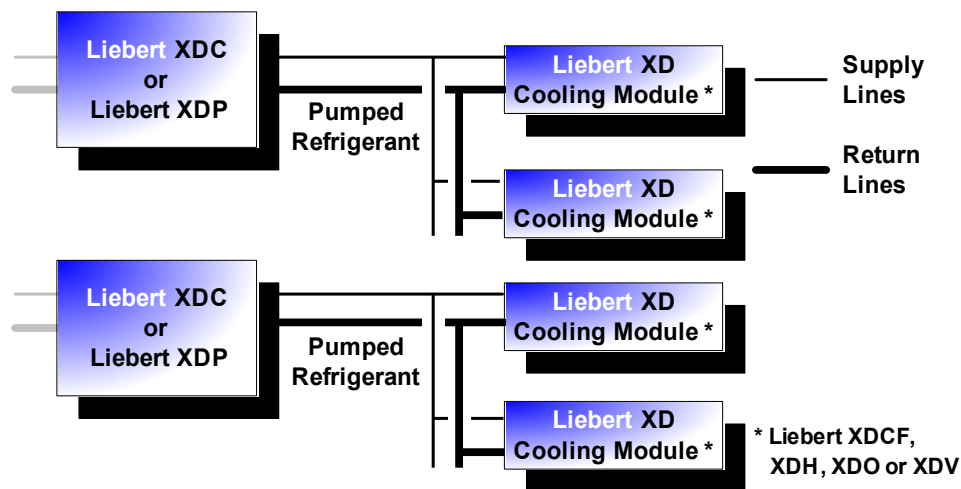
### 3.1 Product/System Description

The Liebert XDV cooling system is designed to be attached to the top of a computer cabinet or rack containing heat dissipating equipment. Two fans draw hot air exhausted from the equipment or from the hot aisle, pass it through a cooling coil and discharge cool air back down to the cold aisle, where the equipment's air intake is located. The Liebert XDV comes from the factory ready to draw heated air through a perforated grille on the back of the unit. The Liebert XDV is easily modified to draw hot air through the bottom of the unit, should that cooling method be better suited to your application.

The complete system consists of Liebert XDV modules, Liebert XDP or Liebert XDC coolant distribution units, power and signal cabling and interconnecting piping, see **Figure 3** below.

A condensate detection option gives notification if any condensation occurs in the Liebert XDV.

**Figure 3** Liebert XDV hydraulic diagram



### 3.2 Checking and Unpacking

When the Liebert XDV is delivered, inspect all items for either visible or concealed damage. Damage should be immediately reported to the carrier and a damage claim filed with a copy sent to Liebert or to your sales representative. If you later find any concealed damage, report it to the shipping company and your local Liebert representative.

Check to be sure all required assemblies and parts have been received.

The Liebert XDV is shipped in a protective carton and secured to a pallet (see **Figures 5** and **6**). Do not remove these protective items from the Liebert XDV before it is at the installation location. When unpacking and handling the Liebert XDV, exercise extra care to prevent damage.

### 3.3 Equipment Inspection

Upon arrival of the unit, and before unpacking, verify that the labeled equipment matches the bill of lading. Carefully inspect all items for either visible or concealed damage. Damage should be immediately reported to the carrier and a damage claim filed with a copy sent to Liebert Corporation or to your sales representative.



#### CAUTION

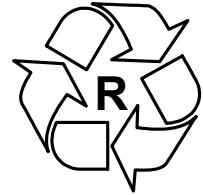
Risk of sudden refrigerant discharge. Can cause loss of charge and minor injury.

If the optional pre-charged option is chosen, the Liebert XDV unit is shipped with a full charge of R-134a refrigerant under pressure. Do not remove the pipe caps or plugs before the unit is ready for connection to Liebert XD Piping.

Supply and return fittings on the pre-charged Liebert XDV units are one-shot connections. Do not disconnect one-shot connections after they have been connected. Disconnection will release pressurized R-134a refrigerant from the Liebert XDV.

#### 3.3.1 Recyclable Packaging

All material used to package this unit is recyclable. Please save for future use or dispose of the material appropriately.



#### WARNING

Risk of improper handling. Can cause equipment damage, injury or death.

Read all of the following instructions before attempting to move, lift, remove packaging from, or preparing unit for installation.



#### CAUTION

Risk of sharp edges, splinters and exposed fasteners can cause injury.

Only properly trained personnel wearing appropriate safety headgear, gloves, shoes and glasses should attempt to move, lift, remove packaging from, or prepare unit for installation.

#### NOTICE

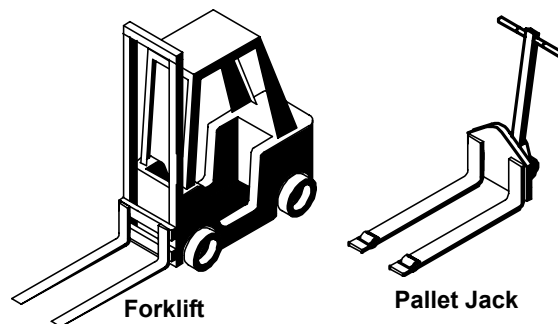
Risk of unit damage if improperly stored. Keep the unit indoors and protected from dampness, freezing temperatures and contact damage.

#### NOTICE

Risk of damage from forklift. Improper handling with the forklift can cause exterior and/or underside damage.

Keep tines of the forklift level and at a height suitable to fit below the skid.

Figure 4 Recommended unit handling equipment



### 3.3.2 Unit Handling

If possible, transport the unit using a forklift or pallet jack.

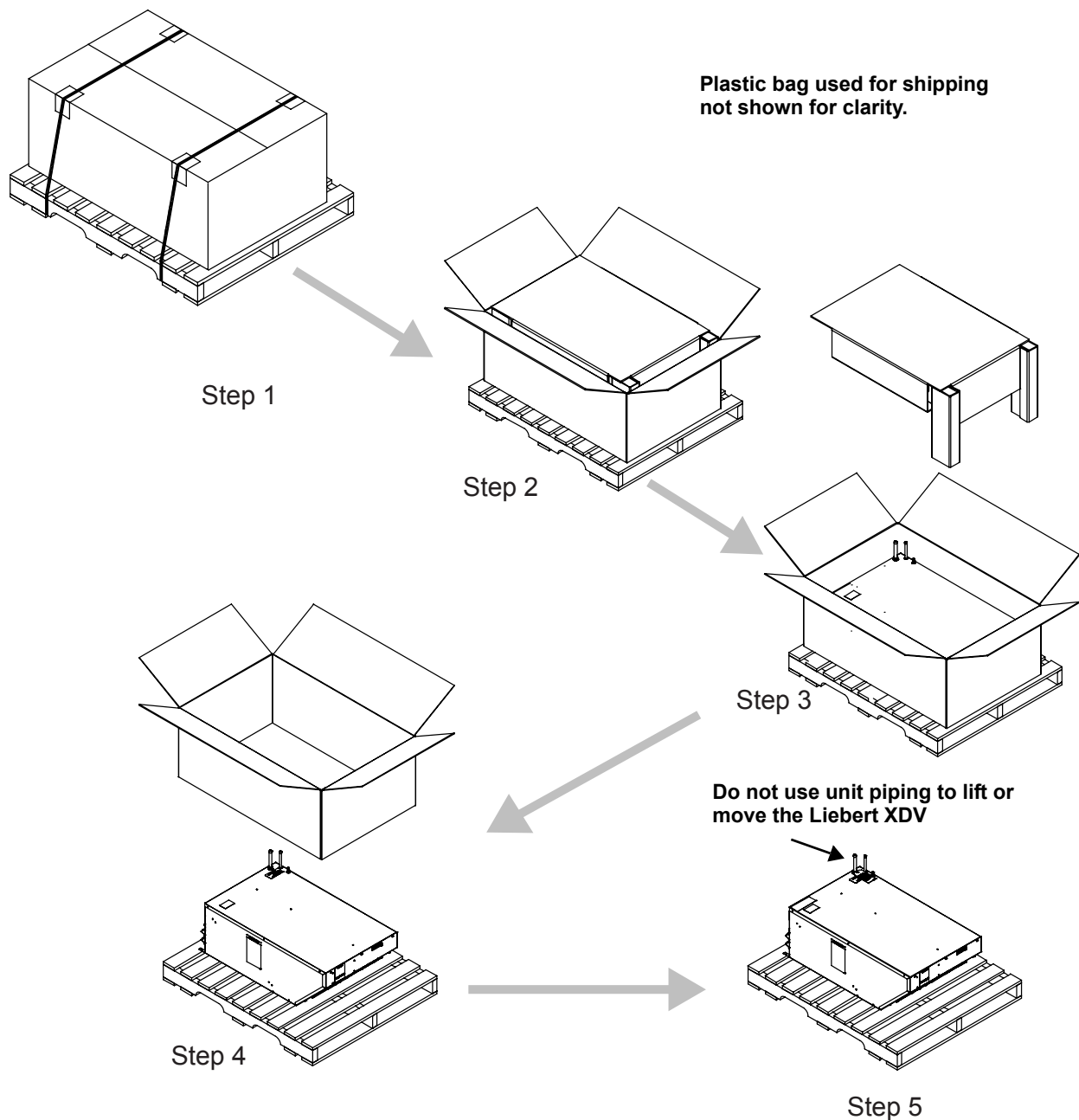
- If using a forklift or pallet jack, ensure that the fork tine length is suitable to safely move the packaged unit.
- Liebert Corporation recommends that the unit remain in the protective packaging until located at the installation site.
- When handling and unpacking the unit, exercise great care to prevent damage.
- Do not use unit piping to lift or move the Liebert XDV

### 3.3.3 Unpacking the Unit

#### Domestic Packaging

1. Remove outer packaging when ready to install the Liebert XDV.
2. Keep the Liebert XDV covered by the unit bag until removal from pallet.

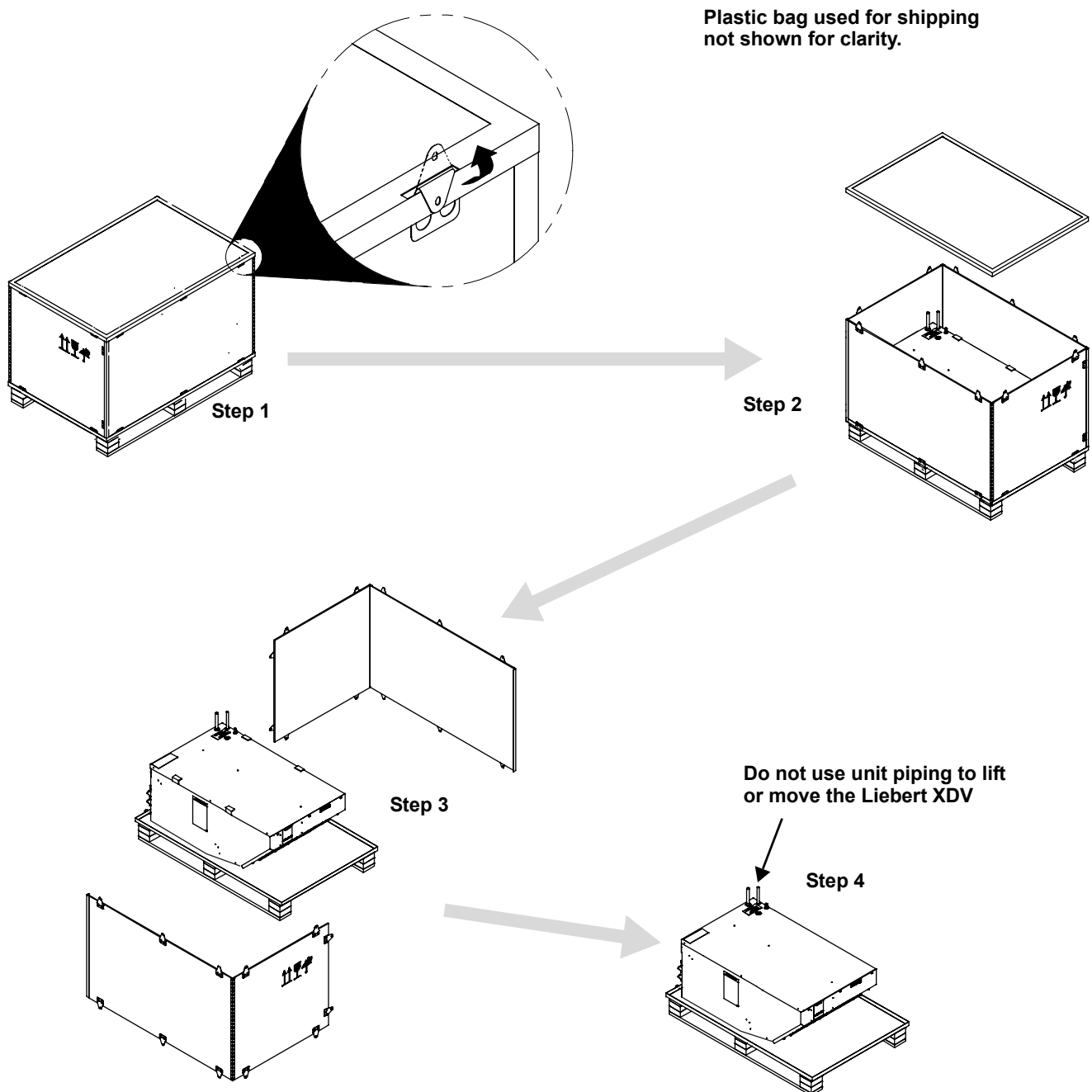
Figure 5 Removing domestic shipping package



### Export Packaging

1. Unbend all metal tabs as indicated in **Step 1** in **Figure 6**.
2. Remove outer packaging when ready to install the Liebert XDV.
3. Keep the Liebert XDV covered by the unit bag until removal from pallet.
4. Do not use unit piping to lift or move the Liebert XDV.

**Figure 6** Removing export shipping package

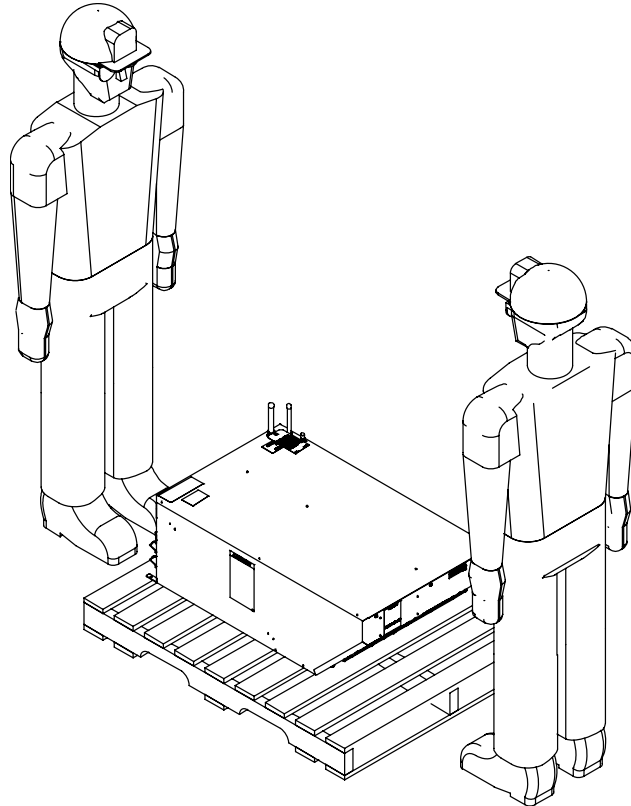


### Removing the Liebert XDV from the Pallet

1. Unfold the unit bag to expose the Liebert XDV.
2. Verify the nameplate information found on the Liebert XDV against the bill of lading. If the information does not match the product specified, contact your local Liebert sales representative.
3. At least two properly trained personnel may lift the Liebert XDV off the pallet and onto a flat surface.
4. To protect the Liebert XDV's paint, lay non-abrasive material, longer than the unit, on the flat surface before moving the Liebert XDV.

**Figure 7 Removing Liebert XDV from shipping pallet**

Removing the Liebert XDV from its shipping pallet requires two people.



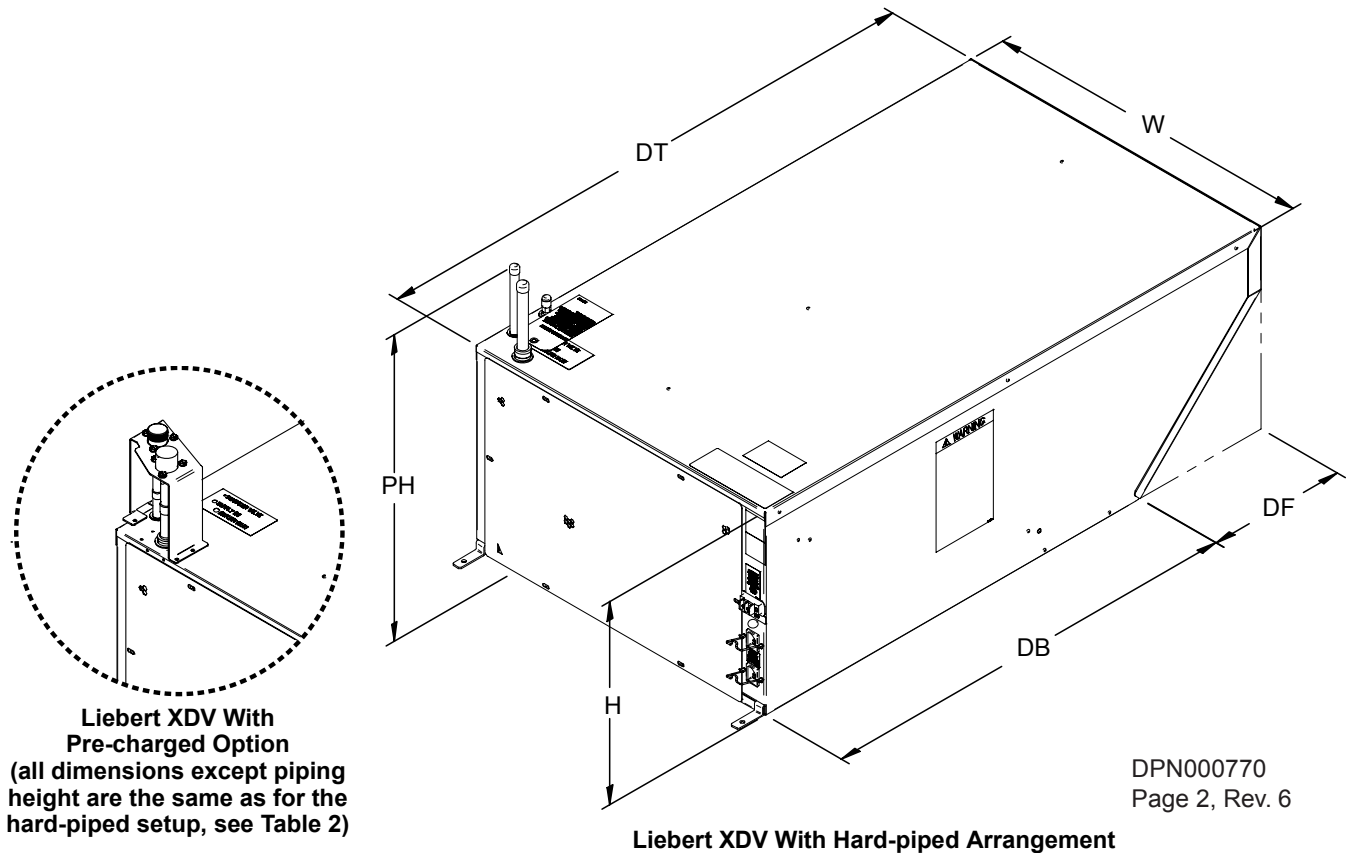
## 4.0 MECHANICAL CONSIDERATIONS

### 4.1 Determining Placement in the Conditioned Space

Liebert XDVs should be placed above or on top of the cabinets that generate the greatest amount of heat. If heat loads are dispersed evenly throughout the room, the Liebert XDV modules may be spread out accordingly.

The Liebert XDV is engineered to fit atop computer enclosure cabinets. **Figure 8**, below, illustrates the unit's dimensions and the location of pipes, the fan tray and power connections. (An optional kit is available to permit suspending the Liebert XDV from either Unistruts or from the overhead structure; see 5.2 - **Suspended Mounting Method**.)

**Figure 8** Liebert XDV dimensions



**Table 2** Dimensional data

Illustration Key	Dimension	Measurement, in (mm)
DT	Depth Top	39-1/2 (1003)
DB	Depth Bottom	29-5/8 (752)
W	Width	22-7/8 (581)
H	Height	14 (356)
PH	Piping Height, hard-piped	18-5/8 (473)
	Piping Height, one-shot option	19-5/8 (498)
DF	Depth Front	9-7/8 (250)

## 4.2 Changing the Air Intake Location

The Liebert XDV comes from the factory with the air intake on the rear of the unit. If required for your application, this can be changed so that the Liebert XDV takes in heated air from the bottom. This is done more easily and safely before the unit is mounted on a computer cabinet.



### WARNING

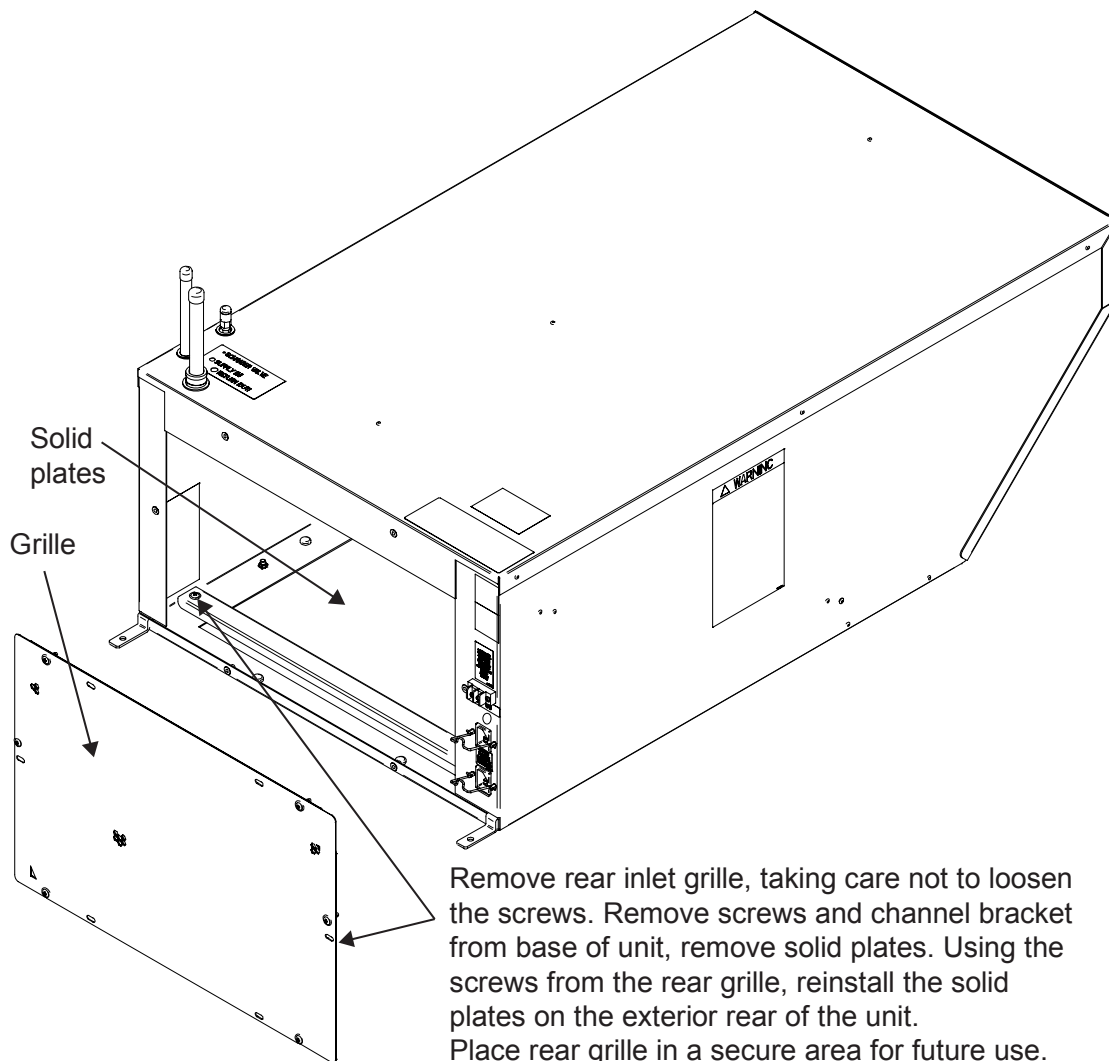
Risk of high-speed moving parts. Can cause death, injury and equipment damage.

Before opening the Liebert XDV, shut the unit off and disconnect all electrical power. Wait for the Liebert XDV's fans to stop rotating before beginning to open the unit.

To change the air intake:

1. Loosen the six screws holding the grille on the rear of the Liebert XDV (see **Figure 9**).
2. Remove the grille and lay it aside for use later.
3. Remove the channel bracket holding the two solid metal plates to the bottom of the Liebert XDV. It is secured with two screws, one on either end.
4. Lift the two solid plates out of the bottom of the Liebert XDV.
5. Optional—replace the channel bracket, securing it with the two screws removed in **Step 3**.
6. Lay the perforated grille down with the screws pointing up
7. Lay the two solid plates on the grille with the screws through the matching holes of the plates.
8. Hold the grille and plates together and attach the assembly to the rear of the Liebert XDV with the screws.

**Figure 9** Changing the Liebert XDV's air intake location



## 5.0 MOUNTING THE LIEBERT XDV

The Liebert XDV module must be securely attached to the top of the computer cabinet or, alternatively, suspended above the cabinet. For mounting atop the computer cabinet, see **5.1 - Mounting the Liebert XDV on Top of the Cabinet**; to hang the Liebert XDV above the computer cabinet, refer to **5.2 - Suspended Mounting Method**. Be sure to follow all applicable codes.



### WARNING

Risk of top-heavy cabinet falling. Can cause equipment damage, injury or death.

A lightly loaded cabinet may become top-heavy after a Liebert XDV is mounted on it, causing the cabinet to tip over, possibly resulting in serious injury.

Before beginning to place the Liebert XDV on the cabinet, ascertain whether the cabinet or rack requires additional stabilization, and secure the cabinet to the floor if necessary to prevent tip-over.

Always use at least two persons to mount the Liebert XDV on top of a cabinet.

### 5.1 Mounting the Liebert XDV on Top of the Cabinet

The Liebert XDV may be installed on a computer cabinet by securing it with either the two included bolts, the two included clips or both the bolts and clips.

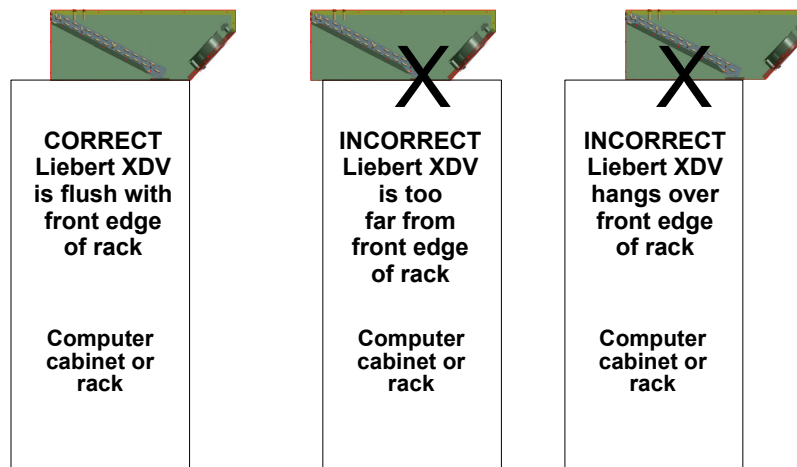
The Liebert XDV has mounting holes below the fans that match holes in the Liebert Foundation computer system cabinet. Other cabinets may require that holes be drilled to accommodate the bolts or the clips.

#### 5.1.1 Bolting Liebert XDV to Top of Cabinet

To mount the Liebert XDV:

1. With at least one additional person, lift the Liebert XDV and set it down on top of the cabinet. The front edge of the Liebert XDV should be even with the front edge of the cabinet. See **Figure 10**.

**Figure 10 Positioning the Liebert XDV**



2. **If your cabinet has mounting holes matching those on the Liebert XDV**, align the Liebert XDV properly and insert the bolts from the bottom of the cabinet and secure them to the factory-installed cage nuts (see **Figure 11**). Tighten the bolts.

**If your cabinet's mounting holes do not match those on the Liebert XDV**, drill holes as required. To prevent metal shavings and particles from falling into the equipment in the cabinet or into the Liebert XDV, use a vacuum or other method to collect them while drilling the holes.

After drilling the holes, insert bolts from the bottom of the cabinet and secure them to the factory-installed cage nuts (see **Figure 11**). Tighten the bolts.

If also using mounting clips in conjunction with bolting method above, see **5.1.2 - Using Supplied Clips for Mounting**.



Figure 11 Mounting hole locations—standard mounting method

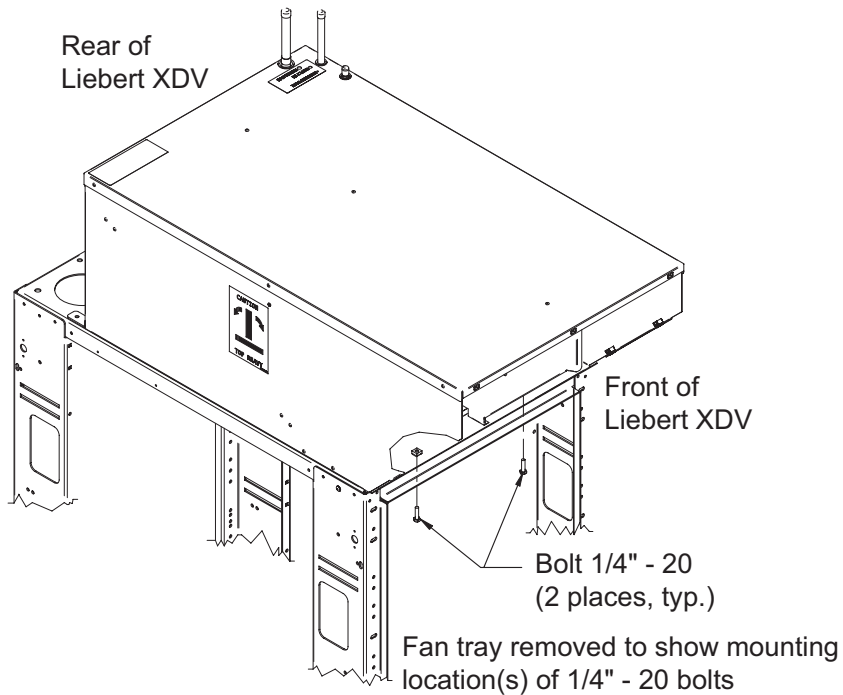
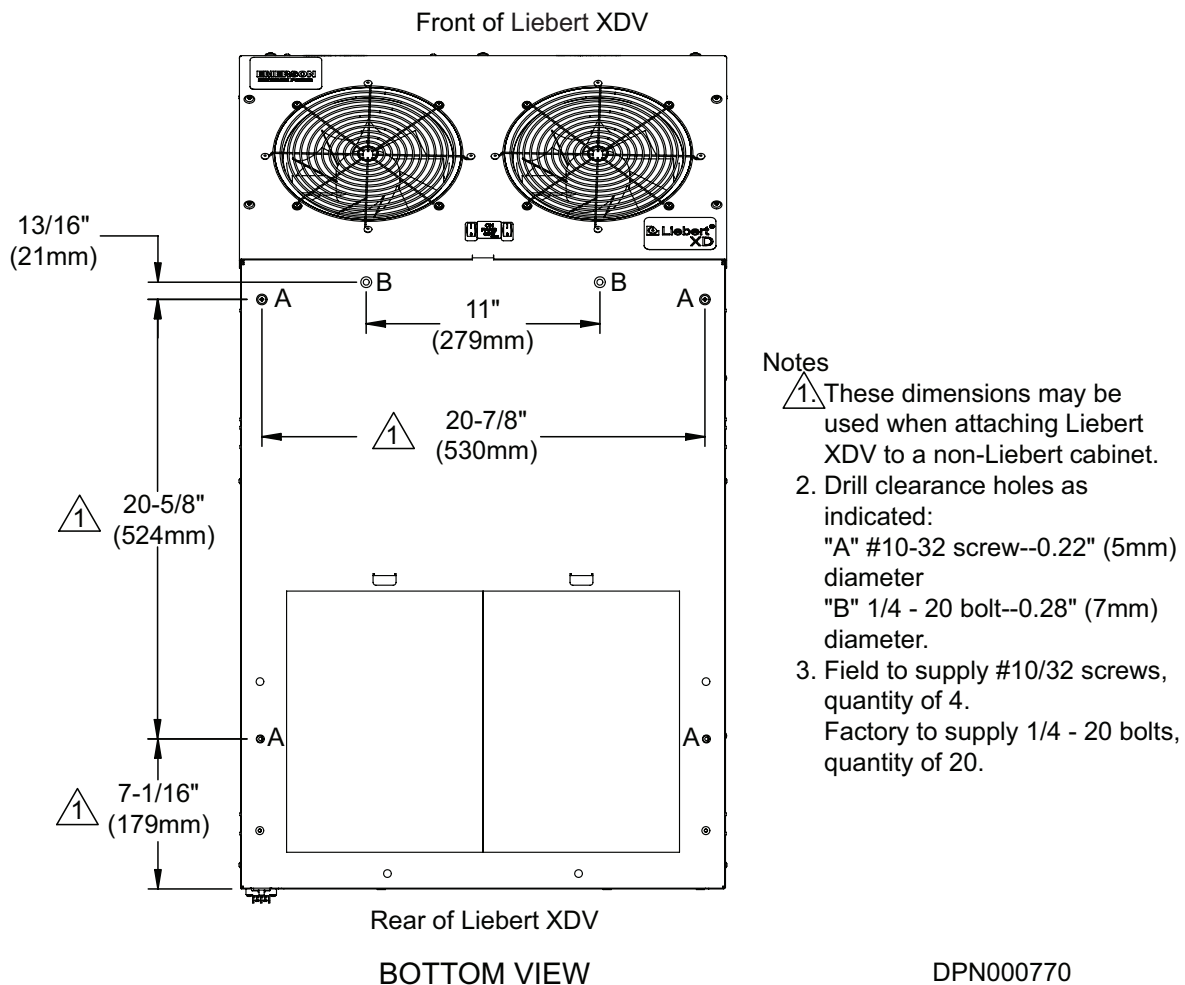


Figure 12 Mounting hole locations—alternate mounting points



### 5.1.2 Using Supplied Clips for Mounting

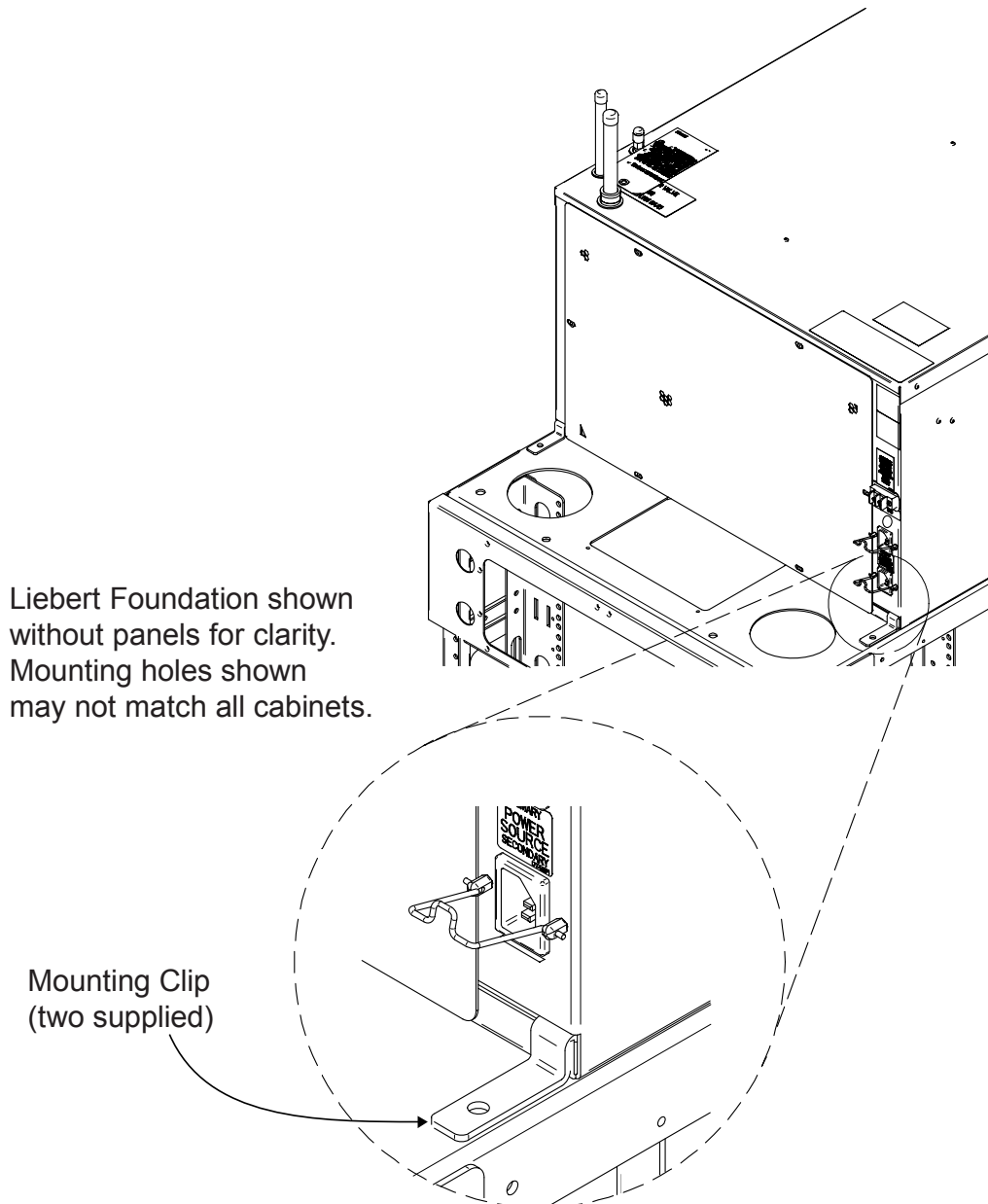
1. Attach the mounting clips to the back of the Liebert XDV by fitting them into the machined slots. Tighten the bolts.
2. **If your cabinet has mounting holes in position for the clips**, align the Liebert XDV properly and insert the bolts from the bottom of the cabinet and secure them with the included lock washers and nuts (see **Figure 13**). Tighten the nuts.

**If your cabinet's mounting holes do not match the clips**, drill holes as required. To prevent metal shavings and particles from falling into the equipment in the cabinet or into the Liebert XDV, use a vacuum or other method to collect them while drilling the holes.

After drilling the holes, insert bolts from the bottom of the cabinet and secure them with lock washers and nuts (see **Figure 13**). Tighten the nuts and bolts.

If also using mounting clips in conjunction with bolting method above, see **5.1.1 - Bolting Liebert XDV to Top of Cabinet**.

**Figure 13** Mounting clip placement



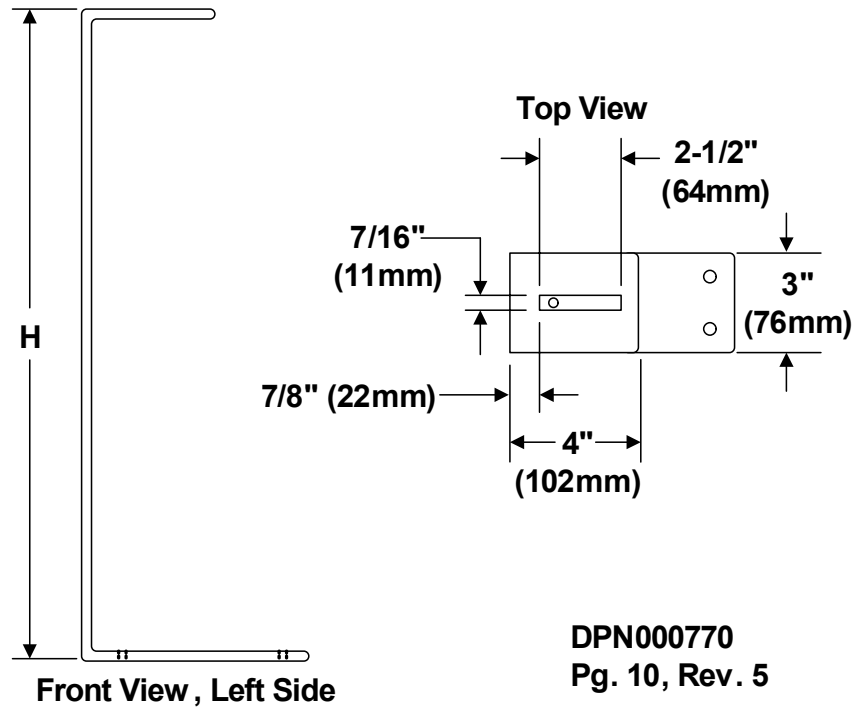
## 5.2 Suspended Mounting Method

The Liebert XDV also may be mounted above the cabinet by suspending it either from overhead components or from Unistruts above the cabinets (see **Figures 15** and **16**). An optional kit available from Liebert will simplify mounting the Liebert XDV above the computer cabinet.

Each suspended-mounting method requires that the supporting components be strong enough to support the Liebert XDV's weight with coolant, 79 lb. (36kg). Each method also requires that the Liebert XDV's placement above the computer cabinet meets the criteria in **Figure 10**.

To ensure efficient cooling, a baffle or similar object must be installed between the suspended Liebert XDV and the computer cabinet (see **Figure 16**). The baffle's purpose is to prevent the Liebert XDV from drawing in the cooled air that it has just discharged.

**Figure 14 Dimensions—optional external hanging brackets**



**Table 3 Suspension hardware and bracket dimensional data**

Bracket Kit Part #	"H"	Liebert XDV Units to be Suspended	Brackets in Kit
180427G1 180427G5	20 (508)	1	4
		5	20
180427G11, 180427G15	34-5/16 (872)	1	4
		5	20
180427G22*	18-11/16 (474)	2	8
	33 (838)		

\* Bracket kit for double-stacked Liebert XDVs

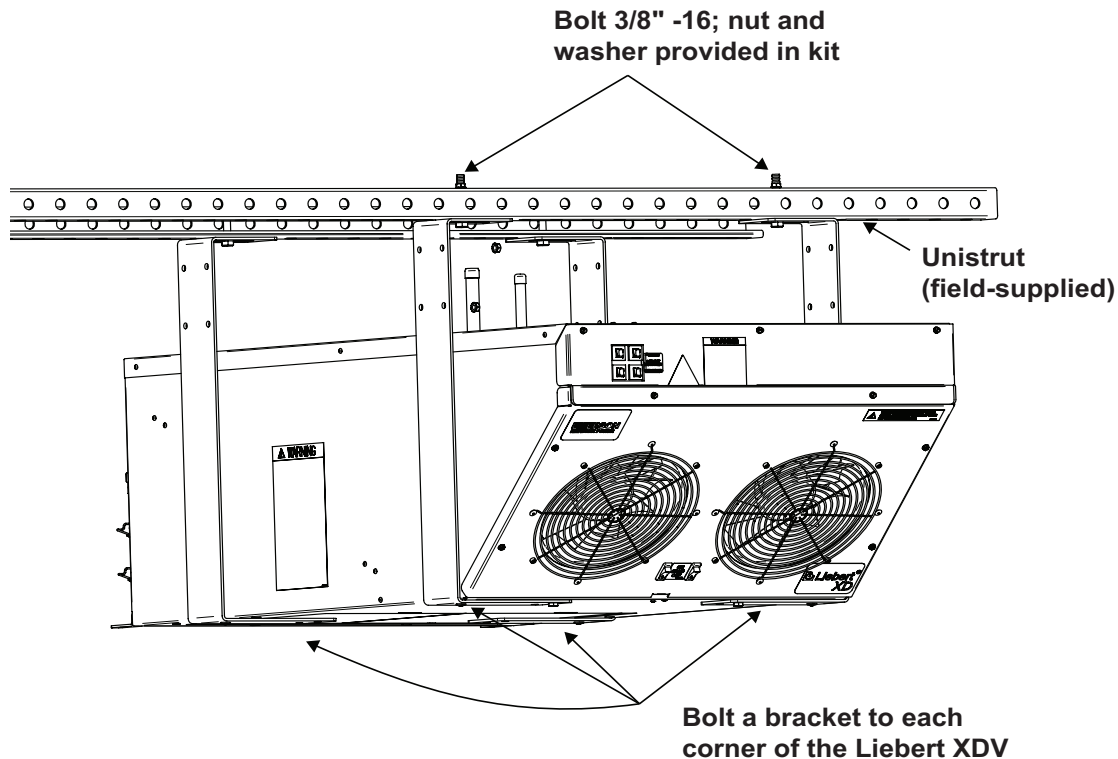
### 5.2.1 Suspending the Liebert XDV from Unistruts

The Liebert XDV may be bolted to customer-supplied Unistruts. The height of the Unistruts above the computer cabinet must be adequate to accommodate the combined height of the Liebert XDV and the baffle.

To suspend the Liebert XDV from a Unistrut system:

1. Bolt the hangers to each corner of the Liebert XDV, inserting the Liebert-supplied bolts into factory-fabricated holes in the bottom of the Liebert XDV. See **Figure 15**.
2. Tighten all bolts firmly, taking care not to overtighten the bolts.
3. Using a lifting mechanism, raise the Liebert XDV with brackets attached, to the proper height and bolt the brackets to the Unistruts.

**Figure 15** Suspending Liebert XDV from Unistruts

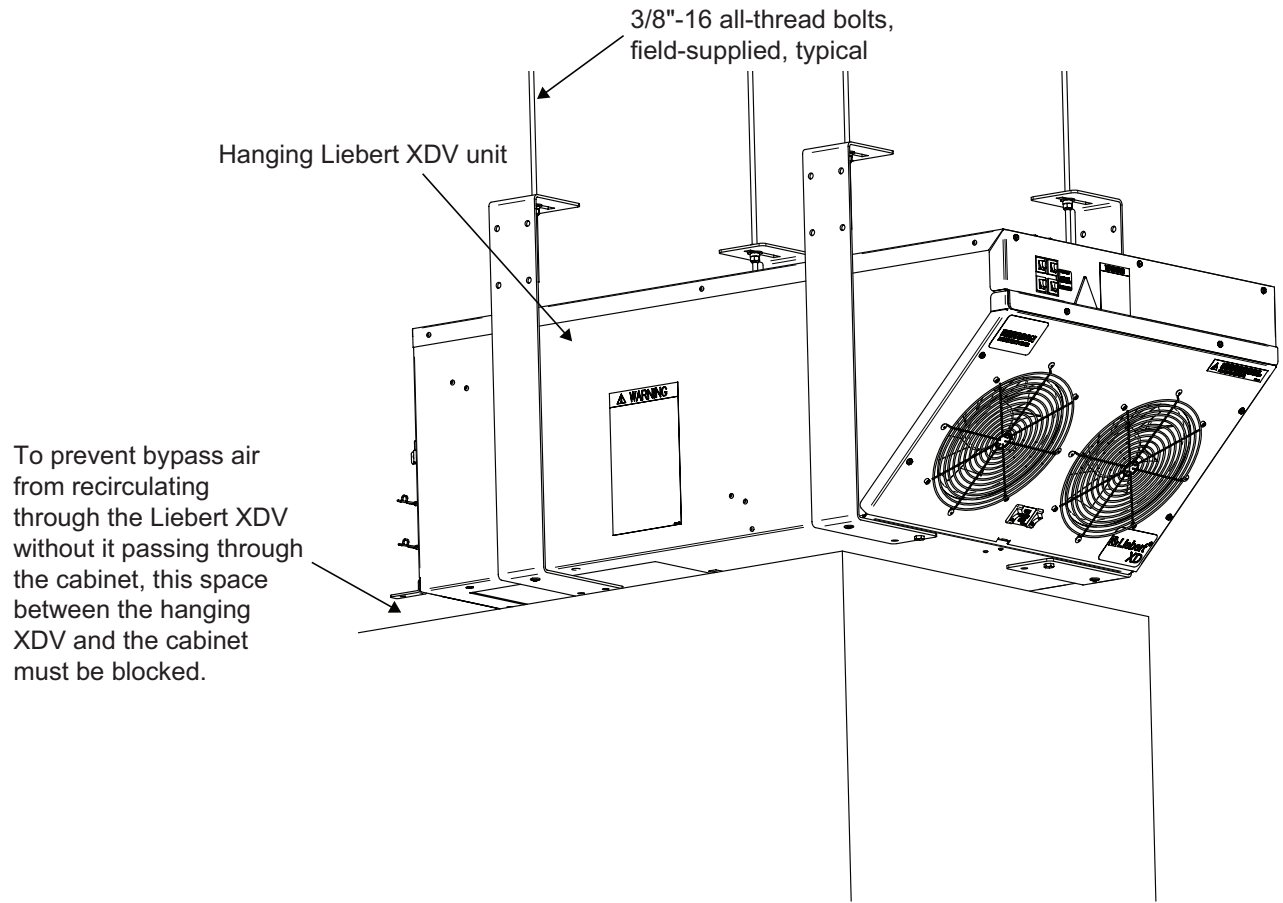


### 5.2.2 Suspending the Liebert XDV from Overhead Structures

To suspend the Liebert XDV from the overhead structure using the optional overhead mounting kit and field-supplied all-thread bolts:

1. Bolt the hangers to each corner of the Liebert XDV, inserting the Liebert-supplied bolts into factory-fabricated holes in the bottom of the Liebert XDV.
2. Tighten all bolts firmly, taking care not to overtighten the bolts.
3. Install the field-supplied all-thread bolts into the overhead structure, securing them to components so they will match the layout of the brackets
4. Using a lifting mechanism, raise the Liebert XDV inserting the all-thread bolts through the bolt holes in the brackets
5. Install field-supplied nuts and washers, on the all-thread bolts, placing them on the bolts at the level desired for hanging the Liebert XDV.
6. Again using field-supplied nuts and washers, secure the Liebert XDV to the all-thread bolts.
7. Tighten the nuts until the Liebert XDV is level and well-secured.

Figure 16 Suspending Liebert XDV from the overhead structure



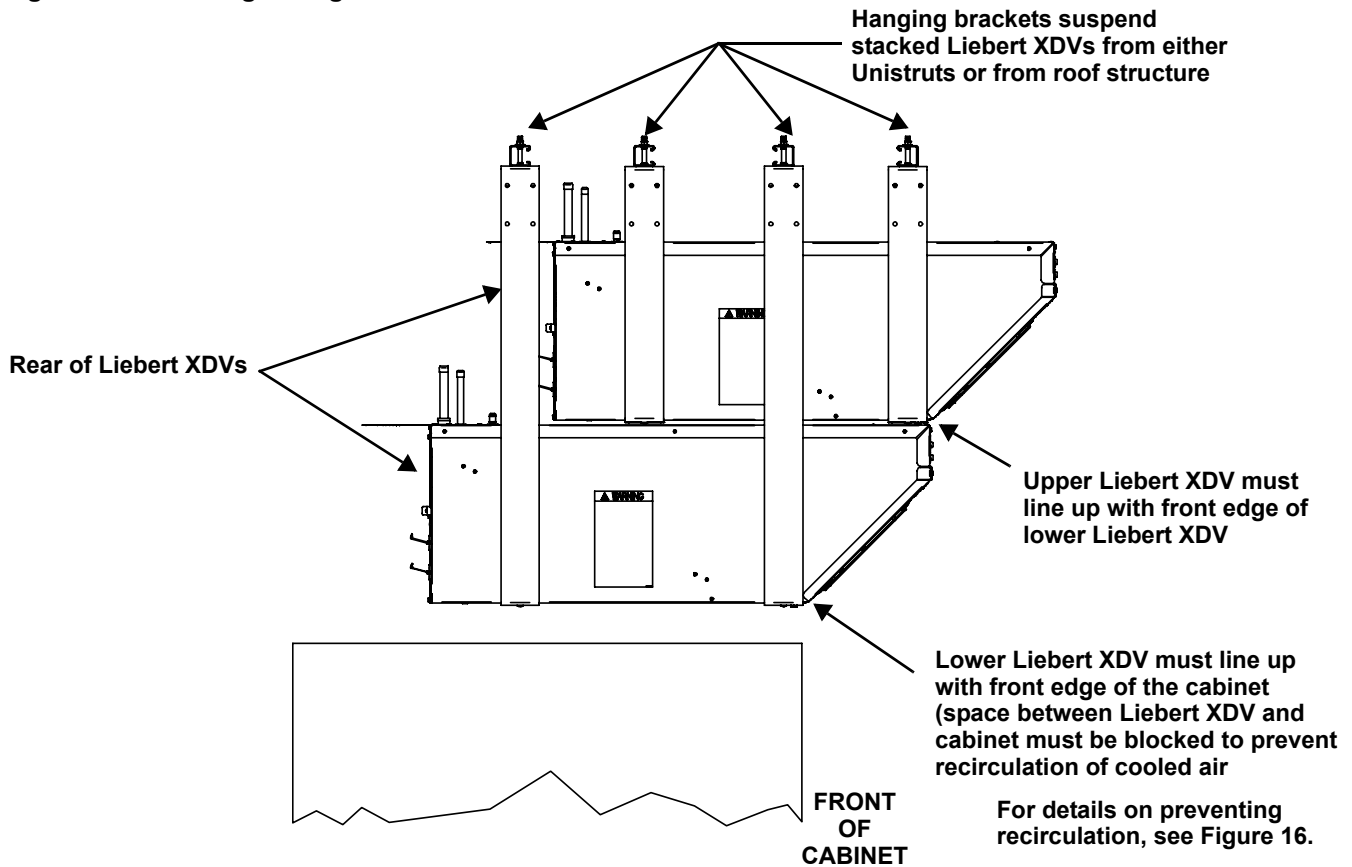
### 5.3 Mounting Liebert XDVs in Stacked Setup

Liebert designed the Liebert XDV to permit mounting the units in a stacked arrangement to increase the system's heat-removal. Stacking may be done either during the original system or added later to an existing configuration.

Stacking Liebert XDVs is possible when suspending units from either Unistruts or from the overhead structure. Hanger brackets are available in two lengths to ease hanging Liebert XDVs in a stacked arrangement.

The upper Liebert XDV must be positioned forward of the front of its companion Liebert XDV for efficient heat removal (see **Figure 17**).

**Figure 17 Stacking configuration offset**

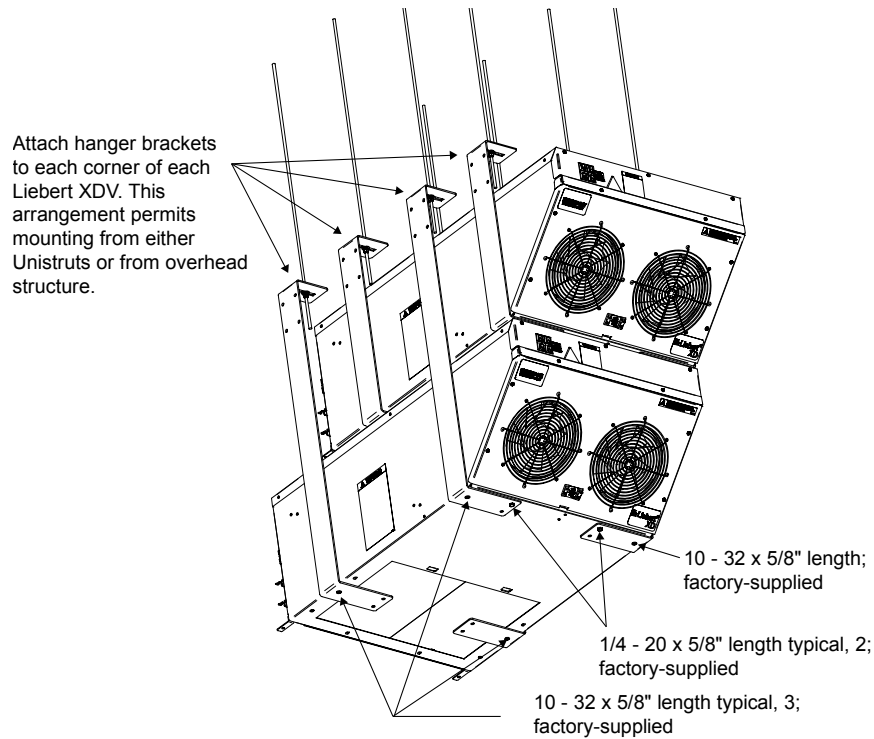


### 5.3.1 Hanging Stacked Liebert XDV's from Unistruts

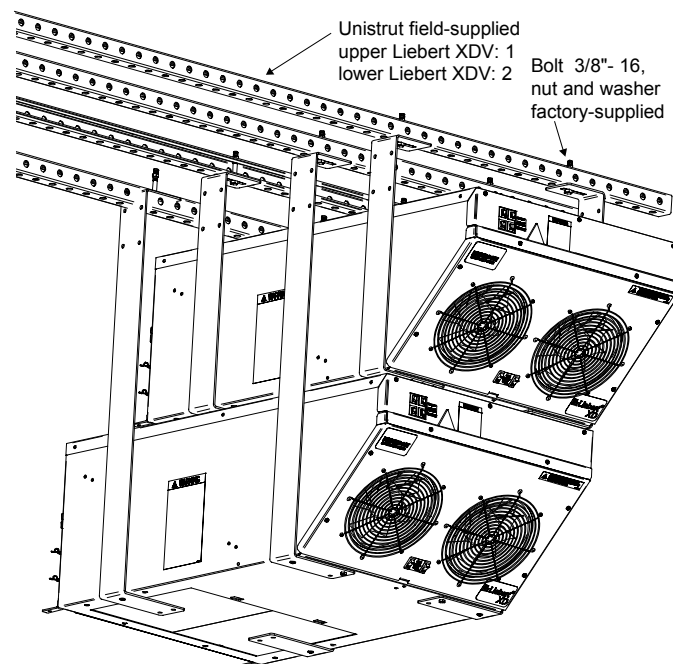
Because the upper Liebert XDV in a stacked arrangement must be positioned farther forward than the lower Liebert XDV, two sets of Unistruts are required. The second set of Unistruts must be installed 9-7/8 inches (251mm) forward of the first set. This arrangement positions the stacked Liebert XDV's so that they meet the air-intake criteria shown in **Figure 10** and **Figure 17**.

After installing the Unistruts at the proper location, hang the Liebert XDV's as outlined in **5.2.1 - Suspending the Liebert XDV from Unistruts**.

**Figure 18 Attach hanger brackets to Liebert XDV for stacked arrangement**



**Figure 19 Stacked Liebert XDV's suspended from Unistruts**

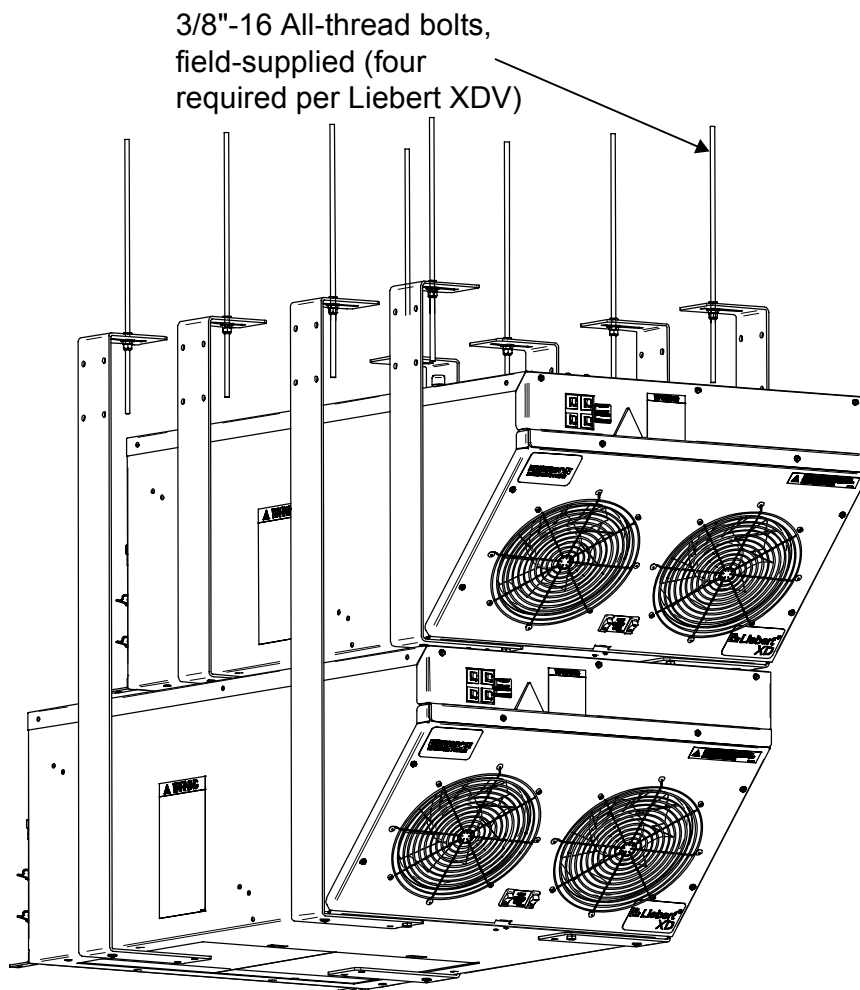


### 5.3.2 Hanging Stacked Liebert XDV's from the Overhead Structure

Because the upper Liebert XDV in a stacked arrangement must be positioned farther forward than the lower Liebert XDV, the place where the hangers attach to the overhead structure must be offset accordingly. The second row of attachment locations must be 9-7/8 inches (251mm) forward of the first row of hanger mounting locations. This arrangement positions the stacked Liebert XDV's so that they meet the air-intake criteria shown in **Figure 10** and **Figure 17**.

After determining the proper for attachment to the overhead structure, hang the Liebert XDV's as outlined in **5.2.2 - Suspending the Liebert XDV from Overhead Structures**.

**Figure 20** Stacked Liebert XDV's ready for suspension from overhead structure





## 6.0 PIPING

### 6.1 European Union Fluorinated Greenhouse Gas Requirements

Stationary air conditioning, refrigeration, heat pump equipments and stationary fire protection systems in the European Community market and operating with fluorinated greenhouse gases (f-gas), such as R407C, R134a, R410A, must comply with the F-Gas Regulation: (EC) No. 842/2006 (F-gas). The regulation prohibits, among other actions, venting fluorinated greenhouse gases to the atmosphere.

The F-Gas Regulation requires operators to use all measures that are technically feasible and do not entail disproportionate cost to prevent leakage of these gases, to test for leakage regularly and to recover f-gas before disposing of equipment, as well as during service and maintenance.

Refer to the full regulation for additional details.

### 6.2 System Connection Configuration

If possible, connect the Liebert XDV modules to Liebert XDPs or Liebert XDCs in an interlaced configuration (see **Figure 21**). In an interlaced configuration, half the cooling units in an aisle are connected to one Liebert XDP or Liebert XDC and the other half in that aisle are connected to another Liebert XDP or Liebert XDC. Such interlaced piping will keep half the Liebert XDV units operating and maintain even cooling in the conditioned space should one of the Liebert XDP or Liebert XDC units fail.

However, in a system with just one Liebert XDP or Liebert XDC, connect Liebert XDV modules in a non-interlaced configuration (see **Figure 22**).

**Figure 21 Typical Liebert XDV piping—interlaced connections**

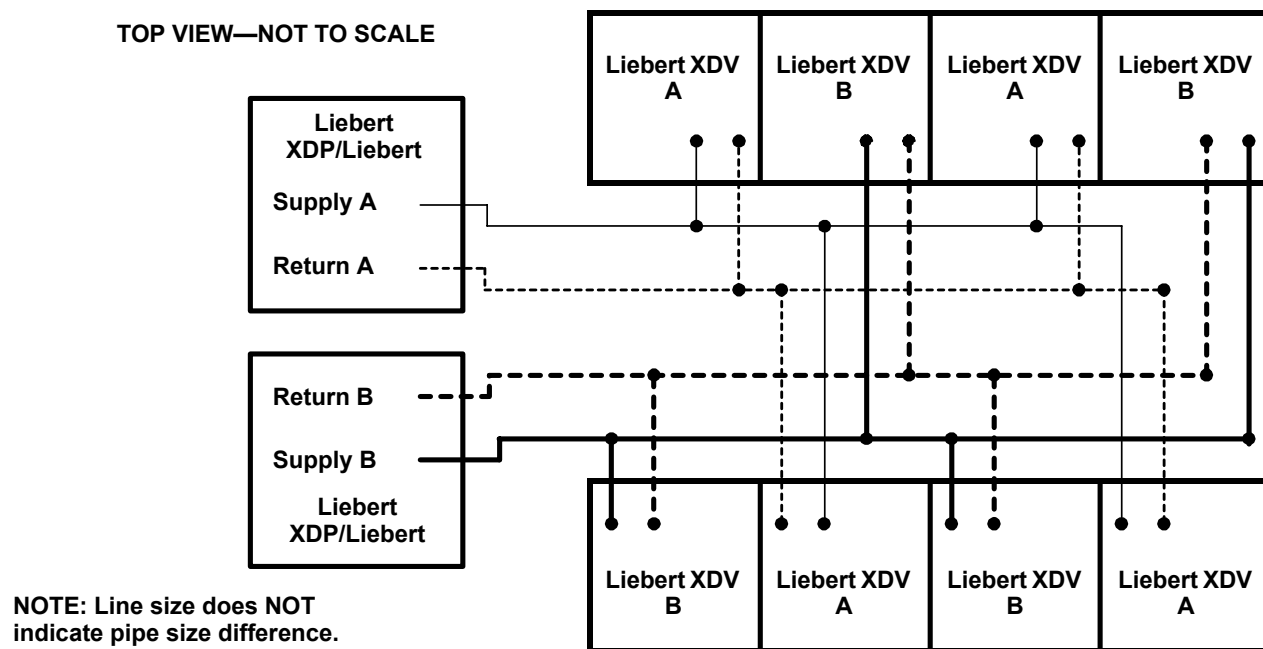
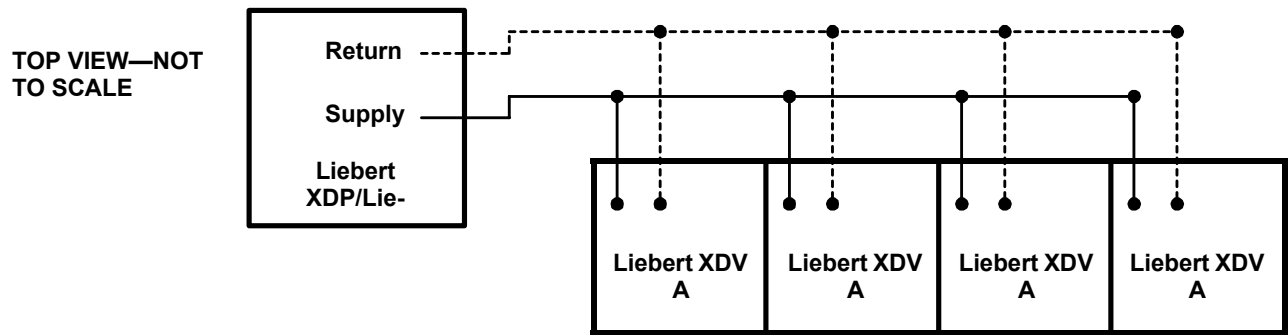


Figure 22 Typical Liebert XDV piping—non-interlaced connection



### 6.2.1 Piping Connections to Liebert XDP or Liebert XDC

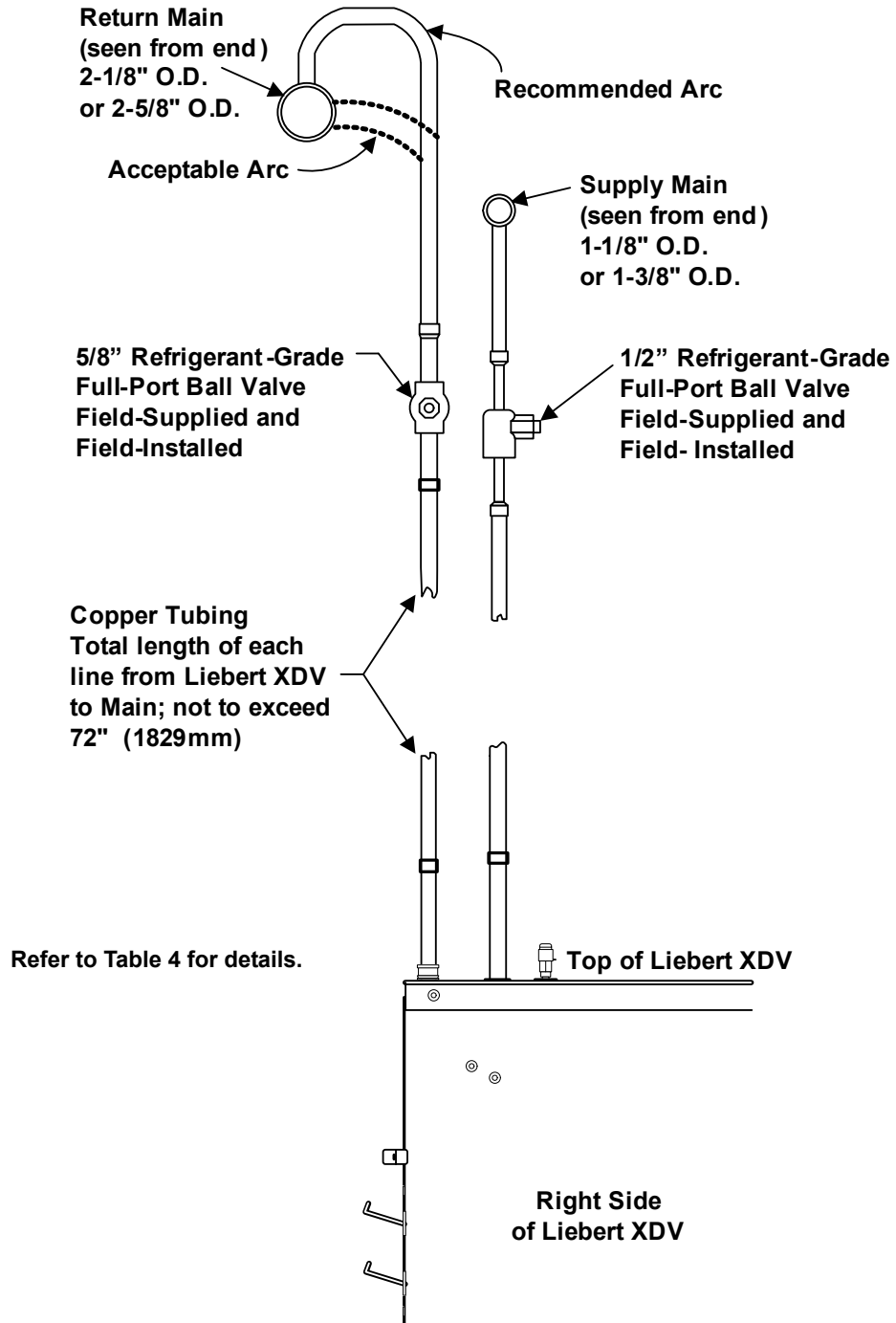
Refer to site specific drawings for general locations of the piping connections. For Liebert XDV connection locations, refer to **Figures 1 and 24**.

### 6.3 Connection Methods and Points

The assembly and connection means used for piping in the Liebert XD system are the same as those used in conventional refrigeration systems. Observe all standard practices during installation and startup to prevent damage and contamination. All piping must be ASTM Type "L" copper pipe.

For hard-piped Liebert XDVs, the supply piping connection is 1/2" OD copper pipe, and the return piping connection is 5/8" OD copper. For Liebert XDVs with the pre-charged option, both supply and return fittings are one-shot connections. These fittings contain pressurized R-134a refrigerant inside the Liebert XDV.

Figure 23 Hard-piped connection diagram



## 6.4 Hard Piped Connection Sizes

Supply piping connection is 1/2" OD copper pipe and return piping connection is 5/8" OD copper.

### 6.4.1 Holding Charge—Hard-Piped Units

The Liebert XDV in hard-piped configuration is shipped with a low-pressure holding charge (about 30 psi) of nitrogen to prevent oxidation and moisture. This must be vented before removing the caps on the ends of the supply and return piping.

To vent the holding charge:

1. Find the Schrader valve that contains the nitrogen holding charge in the Liebert XDV (see **Figure 24**).
2. Vent the holding charge by depressing the pin in the valve.
3. Replace and secure the cap on the Schrader valve.

**Figure 24 Piping location and connection sizes—hard-piped units**

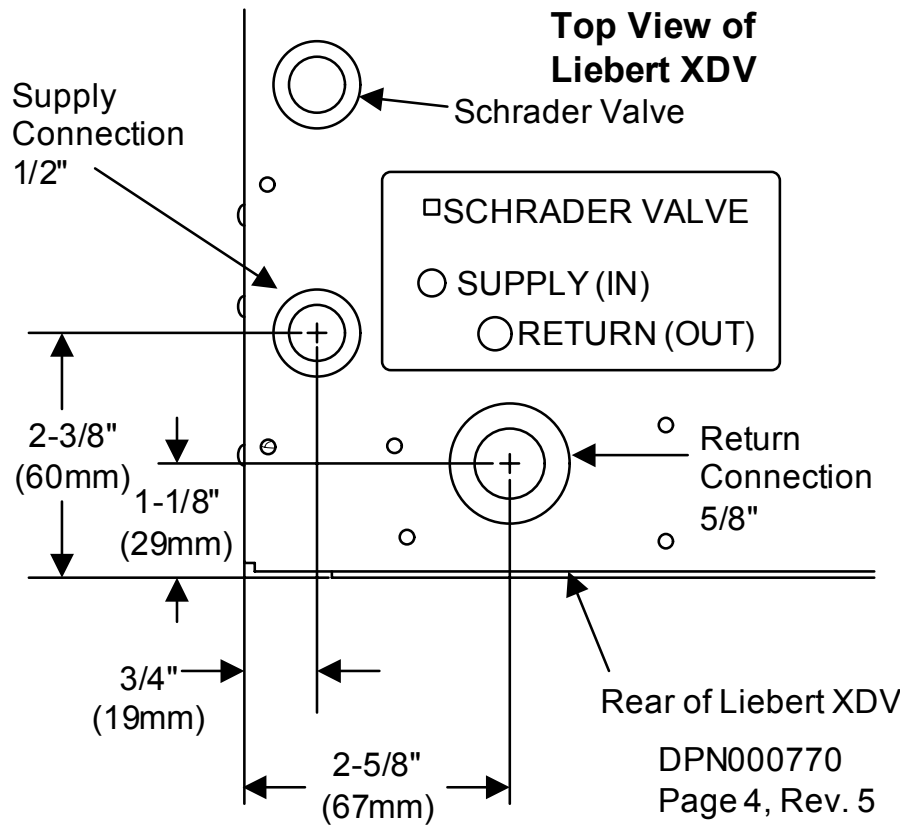
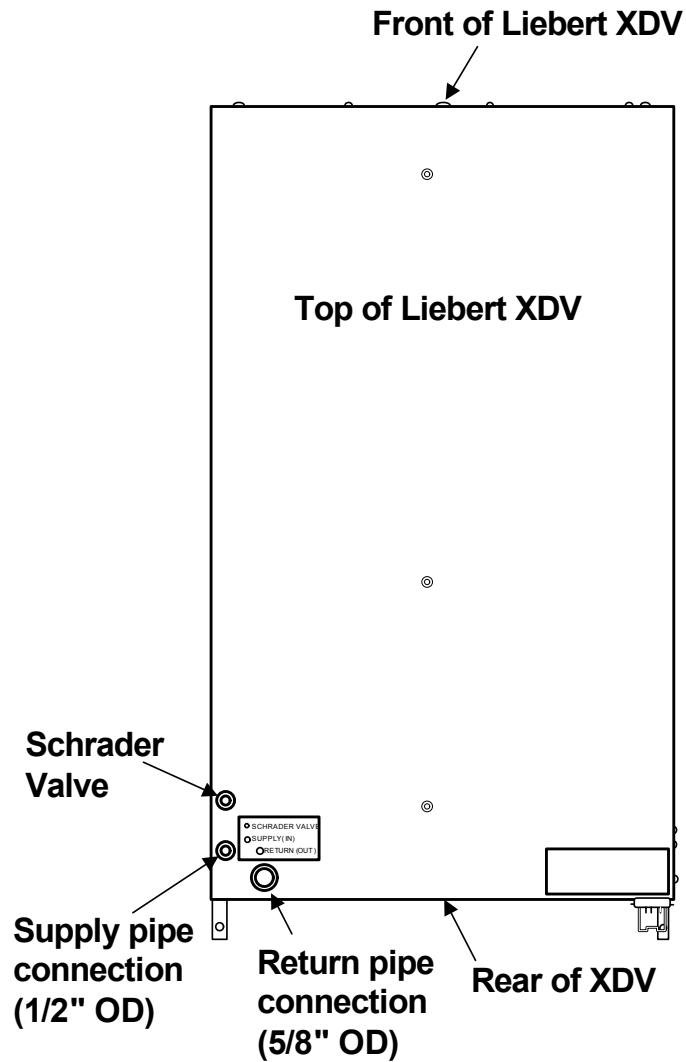


Figure 25 Schrader valve location for venting holding charge



#### 6.4.2 Brazing Preparations—Hard-Piped Units

After the holding charge for a hard-piped Liebert XDV has been vented, a torch can be used to remove the caps over the ends of the supply and return lines.

During brazing, the lines must be filled with flowing dry nitrogen to prevent excessive oxidation and scale formation inside the piping. Prevailing good refrigeration practices must be employed for piping supports, leak testing, dehydration and charging. Failure to use good system practices may result in damage to the system. Refer to the ASHRAE refrigeration handbook for general good-practice refrigeration piping.

#### 6.5 Recommended Piping Size

### NOTICE

To minimize the amount of refrigerant required, do NOT oversize the piping.

Connect the main pipes between the Liebert XDV branch piping and the Liebert XDP or Liebert XDC according to **Table 4**. Elbows and restrictions must be minimized to ensure good fluid flow.

Please see **Table 4** below for recommended pipe sizes and **Figure 3** for piping segment locations.

**Table 4 Branch piping sizes for refrigerant loop**

Pipe Function	Size / Equivalent Pipe Length
Liebert XDP/Liebert XDC supply line, from Liebert XDP/Liebert XDC supply to farthest Liebert XDV	1-1/8" OD (1.025" ID) for lengths up to 60 feet (18m)
	1-3/8" OD (1.265" ID) for lengths over 60 but less than 175 feet (18 to 53m)
Liebert XDP/Liebert XDC return line, from farthest Liebert XDV to Liebert XDP/Liebert XDC return	2-1/8" OD (1.985" ID) for lengths up to 60 feet (18m)
	2-5/8" OD (2.465" ID) for lengths over 60 but less than 175 feet (18 to 53m)
From Liebert XDV supply to supply line of Liebert XDP/Liebert XDC	1/2" OD (0.430" ID) for lengths up to 6 feet (1.8m)
	5/8" OD (0.545" ID) for lengths over 6 feet but less than 35 feet (1.8-10.6m)
From Liebert XDV return to return line of Liebert XDP/Liebert XDC	5/8" OD (0.545" ID) for lengths up to 6 feet (1.8m)
	7/8" OD (0.785" ID) for lengths over 6 feet but less than 35 feet (1.8-10.6m)

### 6.6 Connection Methods—One-Shot Connections

The assembly and connection means used for piping in the Liebert XD system are the same as those used in conventional refrigeration systems. Observe all standard practices during installation and startup to prevent damage and contamination.

Both supply and return fittings may be supplied with optional, one-shot connections. These fittings contain pressurized R-134a refrigerant inside the Liebert XDV.

#### CAUTION

Risk of sudden refrigerant discharge. Can cause injury and loss of charge.

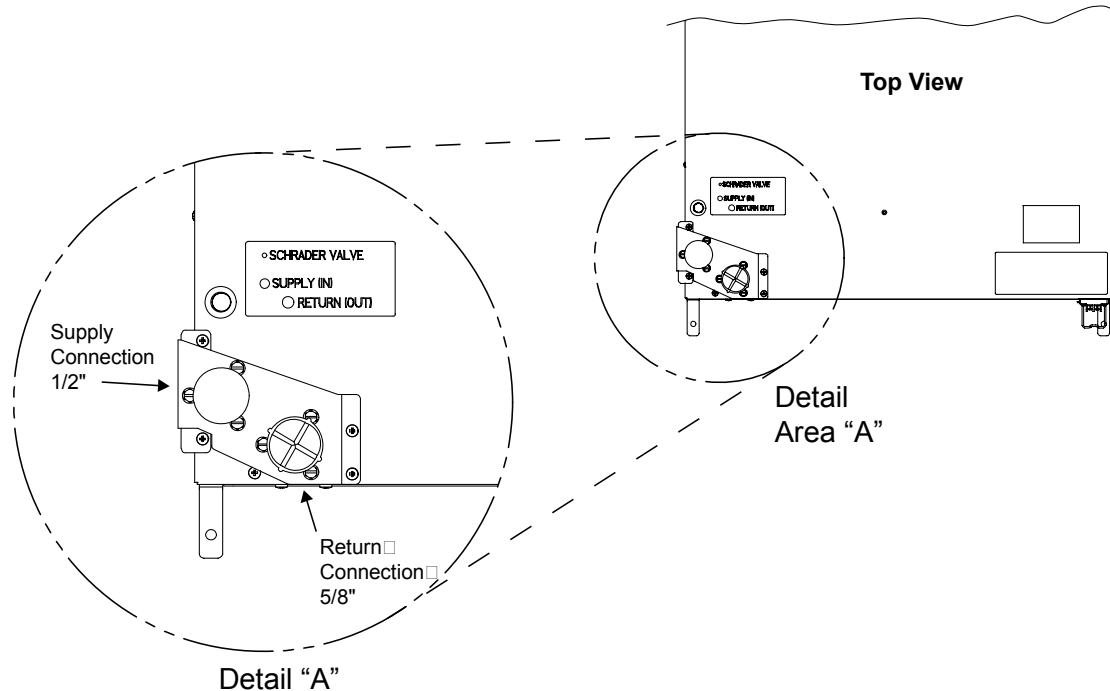
If the optional pre-charged option is chosen, the Liebert XDV unit is shipped with a full charge of R-134a refrigerant under pressure. Do not remove the pipe caps or plugs before the unit is ready for connection to Liebert XD Piping.

Supply and return fittings on the pre-charged Liebert XDV units are one-shot connections. Do not disconnect one-shot connections after they have been connected. Disconnection will release pressurized R-134a refrigerant from the Liebert XDV.

If the unit includes the optional, factory-installed, one-shot style connections, proceed with **6.7 - Field Installation of Liebert Flex Pipe Kit on Liebert XDV** and see **Figure 26**.

If the unit does not include flex piping, refer to **6.4.1 - Holding Charge—Hard-Piped Units**.

**Figure 26 Piping location and connection sizes—pre-charged units with one-shot connections**



### 6.6.1 Refrigerant Charge—Pre-Charged Option

Liebert XDVs with the pre-charged option are equipped with one-shot connections on the supply and return fittings. These contain a charge of R-134a refrigerant under pressure within the unit. This charge must not be vented.

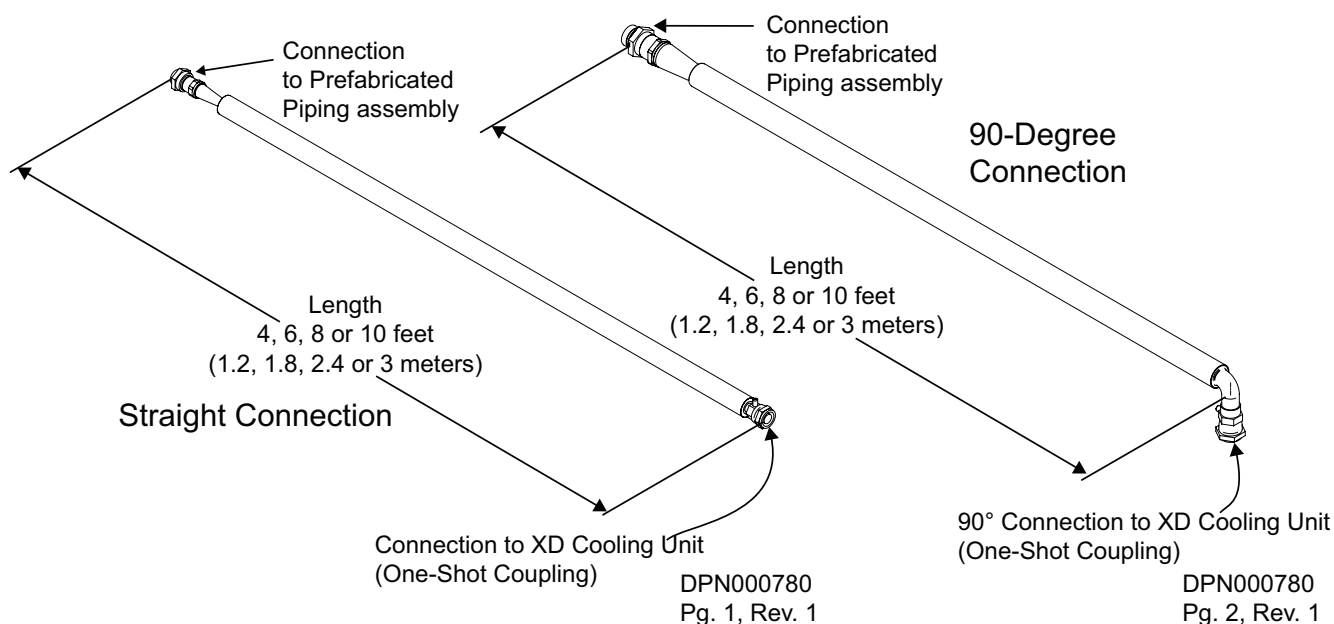
Do not remove the pipe caps or plugs before the unit is ready for connection to Liebert XD Piping. Do not disconnect one-shot connections after they have been connected.

### 6.7 Field Installation of Liebert Flex Pipe Kit on Liebert XDV

If you are not performing a service installation or a field-retrofit, skip this section and proceed with the instructions in **6.8 - Connecting Liebert XD Flex Pipe to Liebert XDV Modules**.

Liebert Flex Pipe kits are available in lengths of 4, 6, 8 and 10 feet (1.2, 1.8, 2.4 and 3 meters). Connection style to the unit end may be straight or 90 degrees. Connection to the prefab piping assembly is a threaded coupler. For data on acquiring the correct kit for your installation, see **Table 7**.

**Figure 27 Liebert XD Flex Pipe dimensions—straight and 90-degree connections**



### 6.8 Connecting Liebert XD Flex Pipe to Liebert XDV Modules

1. Remove the caps on the supply and return lines on the top of the Liebert XDV.
2. Lubricate the threads, diaphragm and O-ring with one or two drops of mineral oil.
3. Connect the line-set coupling finger-tight.
4. Make sure the Schrader valve is properly oriented; refer to the label on the top of the Liebert XDV.
5. Hold the backup hex nut with a wrench while tightening the swivel nut.
6. Tighten the swivel nut on the female coupling until it is seated or a definite resistance is felt.
7. Once a definite bottoming resistance is felt (as in metal to metal), place a mark lengthwise from the swivel nut to the backup hex and tighten the swivel nut on the female coupling an additional 1/4 turn.
8. Tighten both the supply fittings and the return fittings to 35-45ft/lb (47-61Nm).
9. Mark the female and male coupler with for future reference.

## 6.9 Connecting a Liebert XDV with Liebert Flex Pipe to an Operational Liebert XD System

### NOTICE

Before connecting the Liebert XDV with Liebert Flex Pipe to the prefabricated piping mains, check the whole system for leaks.

Check the Liebert XDV to ensure that the unit has no refrigerant leaks.

Read all instructions before beginning installation.

#### Tools Required

- Two adjustable wrenches, with a maximum adjustment size of 2-1/2 inches
- Two ladders
- Lifting mechanism if the Liebert XDV is going to be suspended above the cabinet

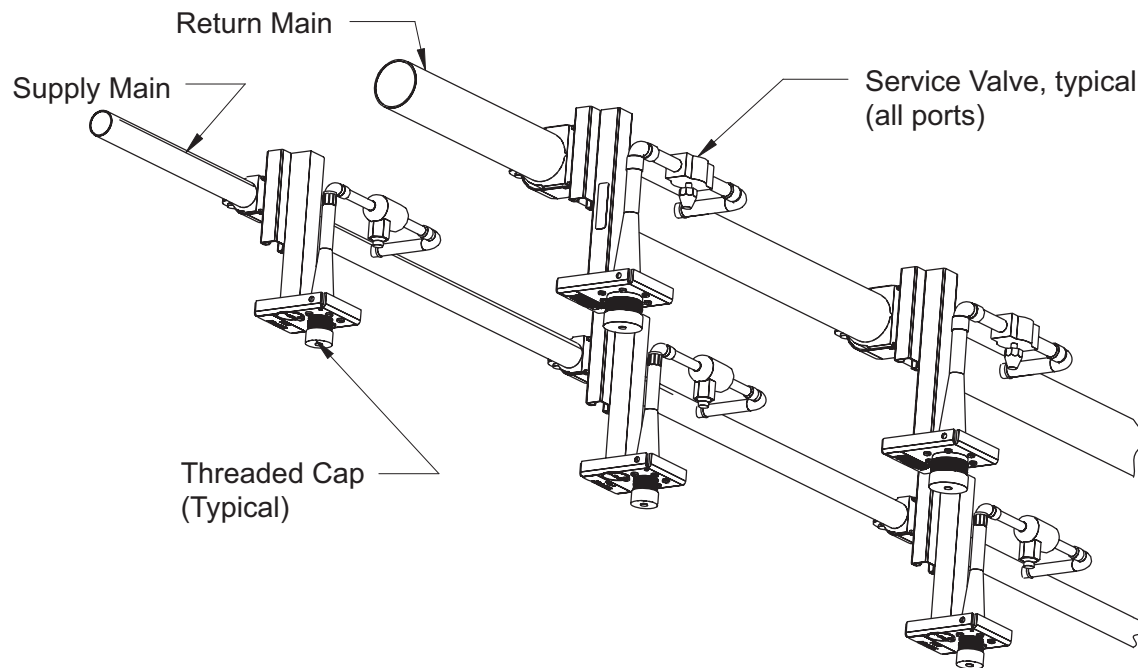


#### NOTE

*This operation requires two or more people.*

1. Determine the port location of the supply and return piping overhead
2. Make sure the service valve for each port is closed
3. Remove cap for only the required ports. Do not remove caps from the unused ports.
4. Once **Step 3** has been completed, remove the pipe plugs that are supplied on the Liebert Flex Pipe on the Liebert XDV.

**Figure 28 Liebert XD prefabricated piping assembly**



5. Use system refrigerant to lubricate the face of the male coupling half, including the poppet valve face and the stainless steel delta ring.
6. Thread the return couplers together, the larger of the two couplers (Liebert Flex Pipe and return main).
7. Use one of the adjustable wrenches to hold the fixed side of the female coupler on the Liebert XDV stationary. With the other adjustable wrench, tighten the collar onto the coupler.

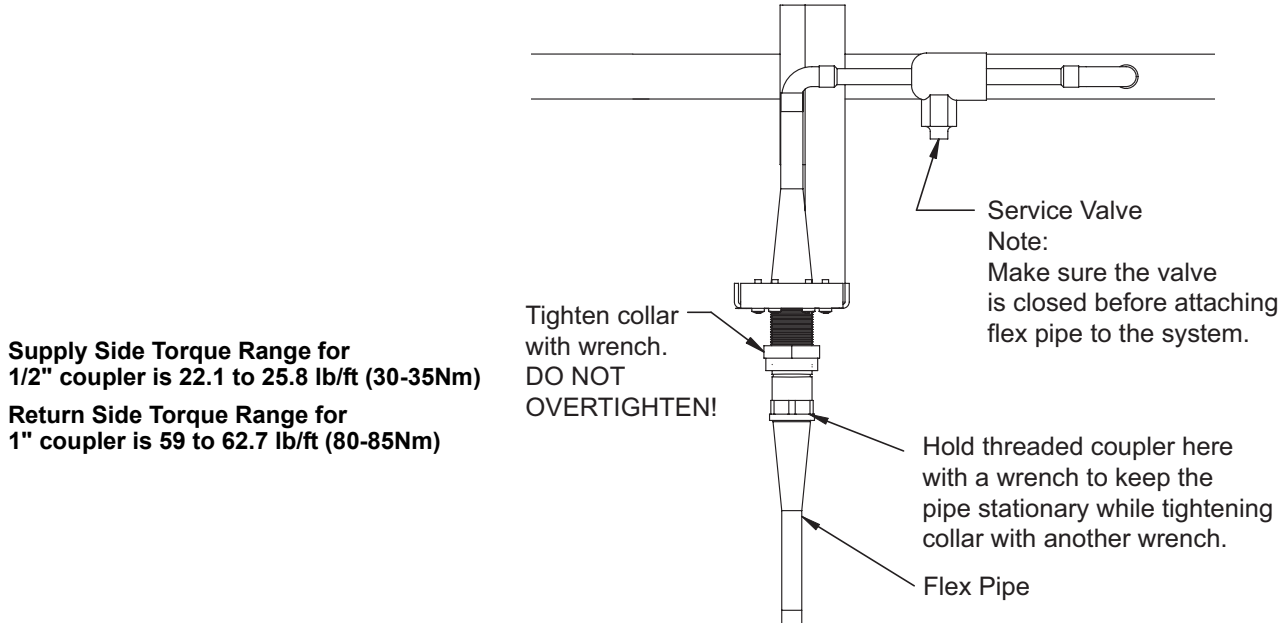
Tighten these only until the force required to tighten abruptly increases. See **Figure 29**.

### NOTICE

Do not overtighten the couplers. Overtightening of couplers will damage the couplers.

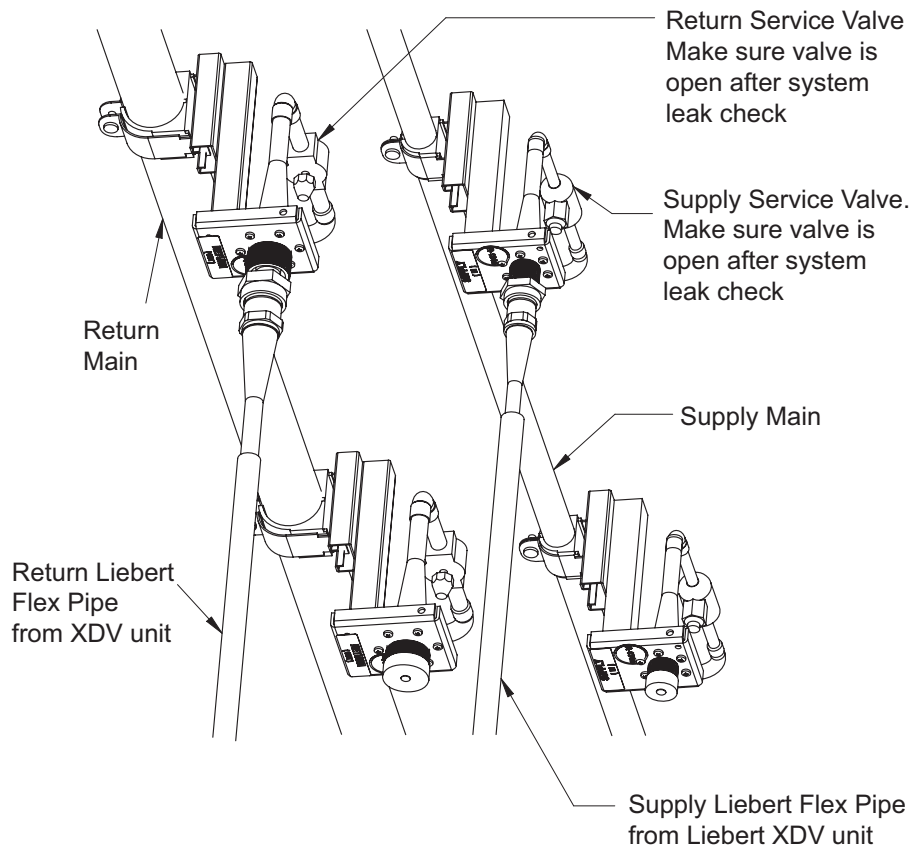


**Figure 29 Detail view of Liebert XD Flex Pipe and prefabricated piping port**



8. Repeat **Steps 6 and 7** for the smaller coupler (supply line).
9. Once the supply and return connections are completed, check to make sure the Liebert XDV fan power switches are Off, then connect the power cords to their power sources.
10. Turn the fan switches on. Ensure that the fans operate.
11. Open the return service valve first, then open the supply service valve.  
With the fans running, cool air is discharged from the front of the Liebert XDV.

**Figure 30 Liebert XD system with prefabricated piping assembly and Liebert XD Flex Pipe**



## 6.10 Disconnecting a Liebert XDV With Liebert Flex Pipe From a Liebert XD System



### CAUTION

Risk of sudden discharge of pressurized refrigerant. Can cause equipment damage or injury. Do not disconnect threaded refrigerant couplers at the unit cabinet end without relieving system pressure. Reclaim any refrigerant during removal of unit from system.

### NOTICE

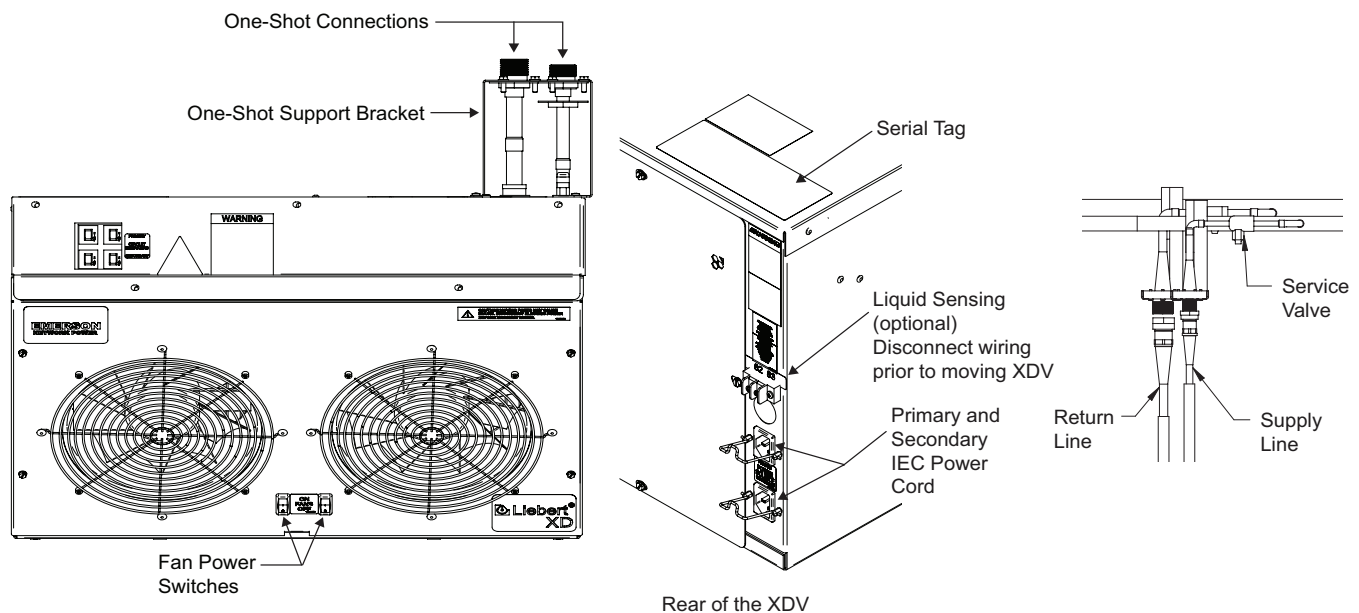
Before uninstalling a Liebert XDV with Liebert Flex Pipe from the prefabricated piping mains: With the fans running, close the supply service valve, wait approximately two minutes, then close the return service valve.

Removing a Liebert XDV from above a cabinet will require two people. Read all instructions before beginning.

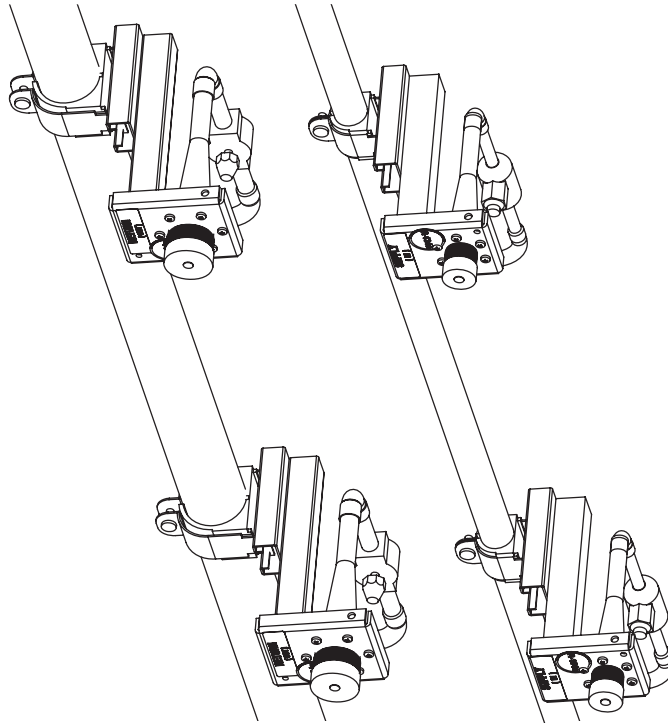
#### Tools Required

- Two adjustable wrenches, maximum adjustment size of 2-1/2 inches
  - Two ladders
  - Phillips head #2 screwdriver
  - Lift mechanism, if the Liebert XDV is suspended above cabinet
1. Ensure the Liebert XDV fan switches are both On and the fans are operational.
  2. Close the service valve in the supply line to the Liebert XDV (smaller coupler).
  3. With the Liebert XDV fans running, wait two minutes.
  4. Close the service valve in the return line to the Liebert XDV (larger coupler).
  5. Turn the fan power switches to the Off position. Once the fan switches are turned Off, unplug the power cords from their power source.
  6. Locate and have at the ready the caps and plugs for both ends of the supply and return couplers.
  7. Loosen the female supply coupler from the male supply coupler (smaller coupler). This requires two adjustable wrenches. Refer to **Figure 29**.
  8. The Liebert XDV side of the female coupler must be held stationary while the collar on the coupler is being loosened. Refer to **Figure 29**.
  9. Disconnect the coupler.

**Figure 31 Profile view of the Liebert XD system with one-shot connections**



10. Place the protective dust cap and plug back onto both ends of the coupler on the Liebert XDV and the port pipe.

**Figure 32 Piping mains without Liebert XDV and Liebert Flex Pipe**

11. Repeat **Steps 8** through **10** for the return coupler (larger coupler).
12. Carefully lay the Liebert Flex Pipe on the top of the Liebert XDV.

## NOTICE

- Risk of permanent damage to the flex pipes. Do not fold or bend flex pipe tightly.
13. Carefully unbolt the Liebert XDV from the cabinet or hanging bracket, if applicable.
  14. With the help of another person, carefully lower the Liebert XDV from the cabinet or hanging bracket onto a stable surface.

### 6.11 Insulation

To minimize the possibility of condensation, insulate all piping between the Liebert XDV and the Liebert XDP or Liebert XDC.

## 7.0 ELECTRICAL

The unit must be installed in accordance with national wiring regulations. Refer to the unit's serial tag for electrical requirements. Refer to **Table 5** for details.

Replacement of any wiring or supply cord must be performed only by the manufacturer, the manufacturer's service agent or a similarly qualified person.

### 7.1 Connecting High Voltage Cables for CSA/C-US Certified Units



## WARNING

Risk of electric shock. Can cause injury or death.

Disconnect all local and remote electric power before working within the unit.

Connect IEC power cords to each receptacle on the Liebert XDV and to power sources. If only one power source is available, then only the power connection labeled "SECONDARY" should be connected to the power source. See **Figures 33** and **34** for location of power connections.

**Figure 33** Liebert XDV electrical connections for CSA-approved units

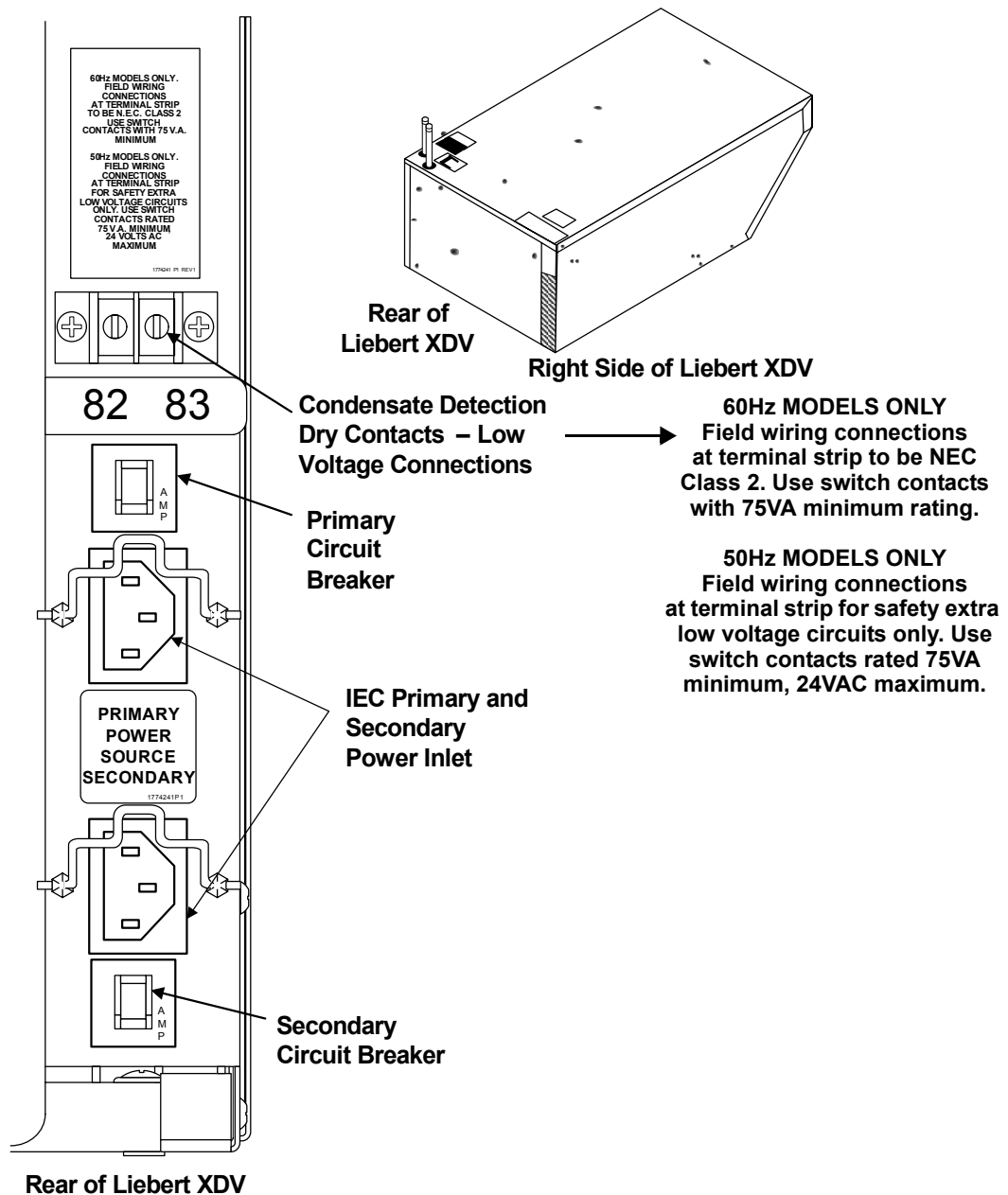
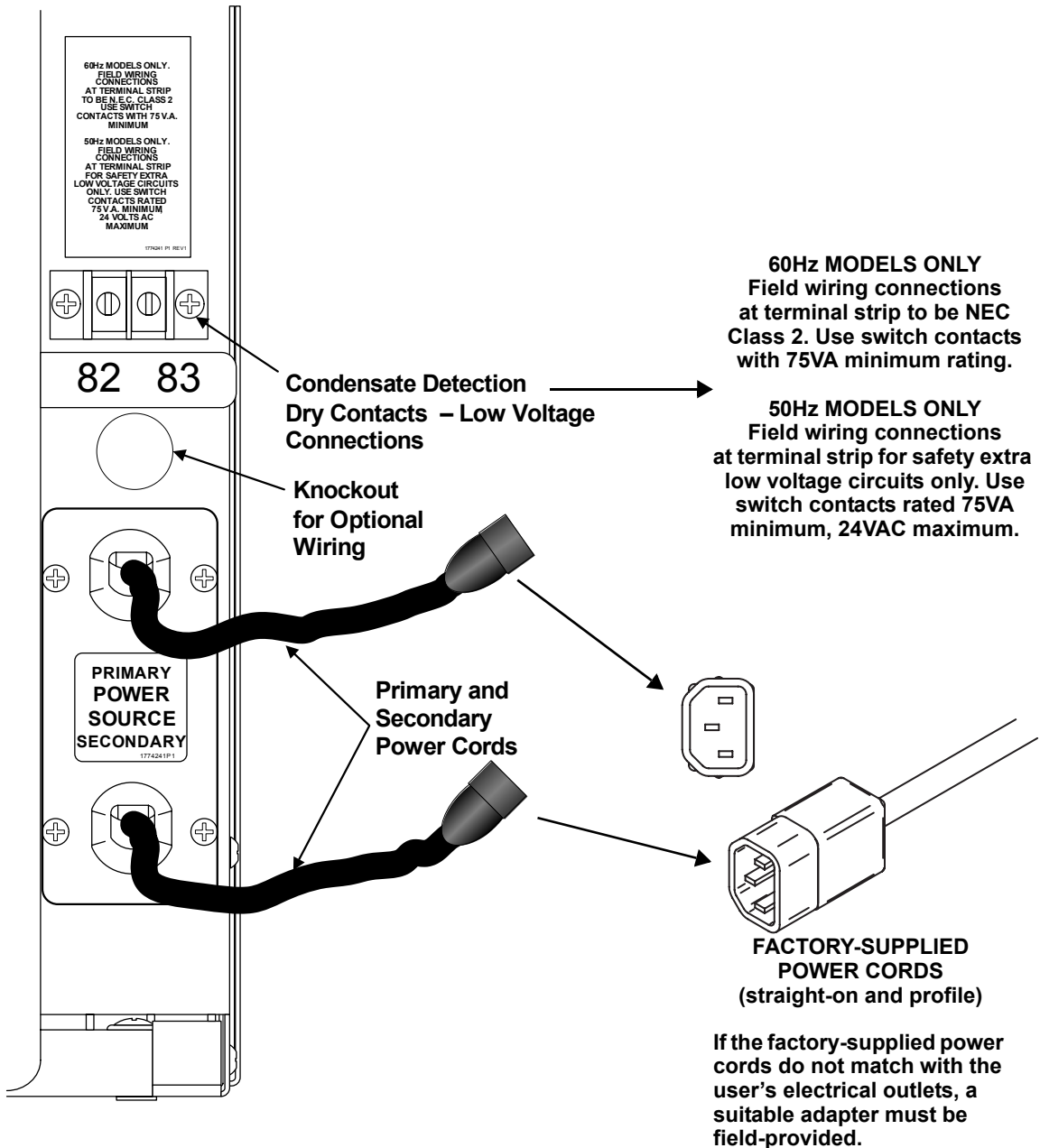


Figure 34 Liebert XDV electrical connections for CE-approved units

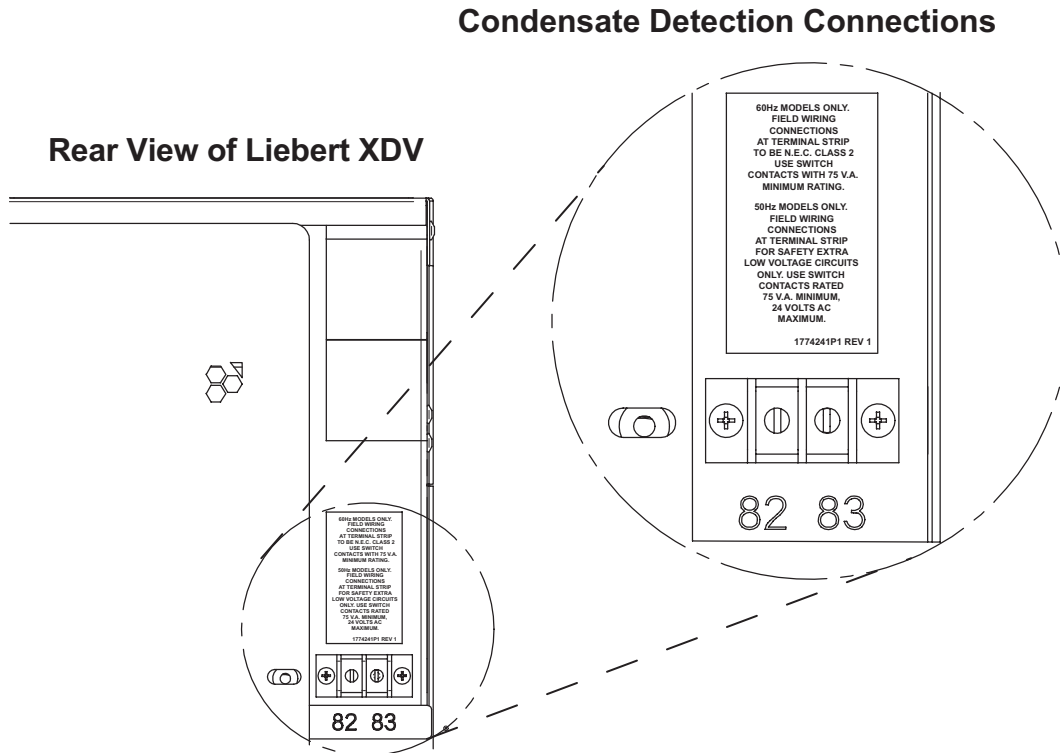


## 7.2 Connecting Low Voltage Wiring—Optional

Low voltage connections to the Liebert XDV are available only on units with the optional condensate detection feature. The low voltage connections are on the right side of the electrical connections box, just above the power connections (see **Figure 35**). These dry contacts can to be connected to a monitoring unit, such as Liebert’s SiteScan®.

For units equipped with condensate detection, make low voltage connections according to site-specific drawings. The unit must be installed in accordance with national wiring regulations.

**Figure 35 Low voltage connections**



## 8.0 INSTALLATION CHECKLIST AND SYSTEM FILL FOR STARTUP

---

### 8.1 Checklist for Proper Installation

- 1. Liebert XDV module is properly mounted, secured either to the cabinet, overhead structure or to the Unistruts.
- 2. Power cords connected to electrical supply.
- 3. Low voltage wiring to optional condensate detection on Liebert XDV.
- 4. Piping from Liebert XDP to Liebert XDV, with isolation valves piped to each Liebert XDV.
  - a. Hard-piped units connected to prefabricated headers
  - b. Flex piping connections to prefabricated header assembly, if flex piping is used.
- 5. Piping insulated.
- 6. Start the Liebert XDV to ensure proper operation (see **9.1 - Start the Liebert XDV**).
- 7. Shut down the Liebert XDV.

### 8.2 Charging with Refrigerant and Starting the Liebert XD System

The Liebert XD System must be completely installed before it is charged with refrigerant. After installation is complete, refer to the Liebert XDP or Liebert XDC user manual for instructions on charging the Liebert XD modules with refrigerant and starting the system. The complete Liebert XD system includes all cooling modules, a Liebert XDC **or** Liebert XDP unit and any other connected equipment.

## 9.0 OPERATION

The Liebert XDV's fan controls are on the front of the unit, near the fans, for easy access. Each switch controls the operation of one fan (see **Figure 36**). The separate switches permit the use of only one fan at a time, reducing the airflow if the Liebert XDV's full cooling capacity is not needed.

The Liebert XDV's primary and secondary circuit breakers are also on the front of the unit. They are at the top left when facing the Liebert XDV (see **Figure 36**).

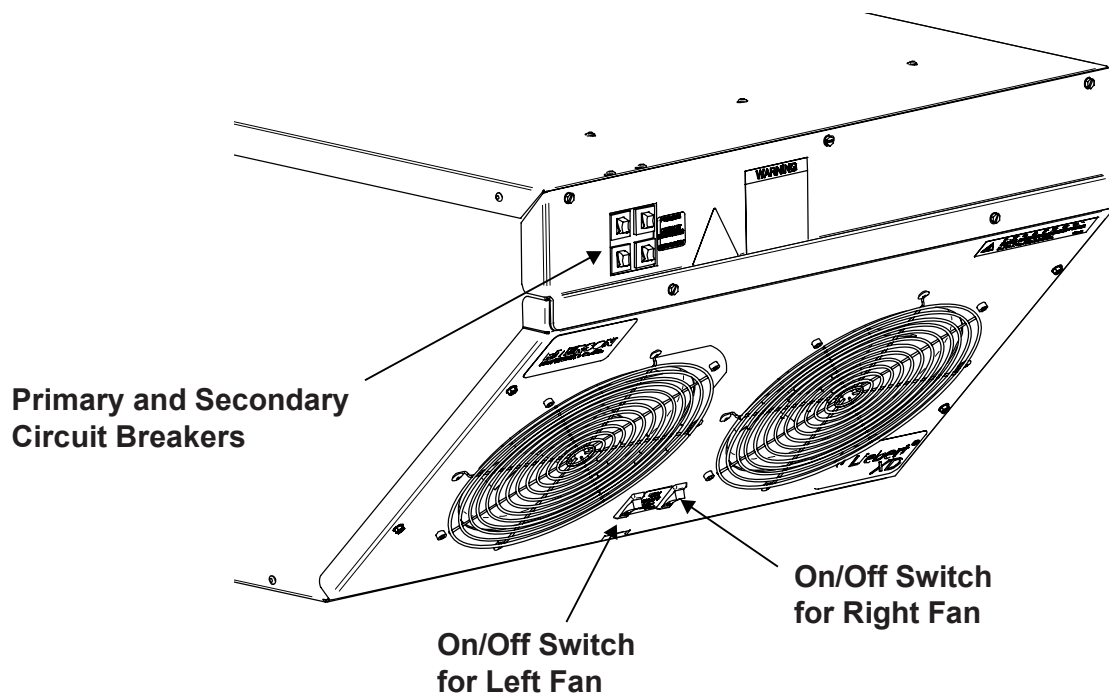


### NOTE

*One of the Liebert XDV's fans must be turned on before either the Liebert XDP or Liebert XDC is switched on.*

*One of the Liebert XDV's fans must be operating at all times that the Liebert XDP or Liebert XDC is operating. Operating either the Liebert XDP or the Liebert XDC without at least one of the Liebert XDV's fans rotating may cause a system malfunction.*

**Figure 36 Fan switches**



### 9.1 Start the Liebert XDV

The Liebert XDV fans must be on before starting the Liebert XDP or Liebert XDC that will supply coolant to the Liebert XDV's.

To start the Liebert XDV, press either of the rocker switches to turn on one or both of the Liebert XDV's fans.



---

## 10.0 MAINTENANCE

---

Minimal maintenance is required to keep the Liebert XDV operating at optimal levels. The unit should be cleaned and checked for damage and worn parts. Suggested maintenance includes:

- Cooling fins—Clean any dust and debris from the cooling fins, taking care not to bend them
- Circulating fans—Clean any dust from the fans.

### 10.1 Fluorinated Greenhouse Gas Requirements

Stationary air conditioning, refrigeration, heat pump equipments and stationary fire protection systems in the European Community market and operating with fluorinated greenhouse gases (f-gas), such as R407C, R134a, R410A, must comply with the F-Gas Regulation: (EC) No. 842/2006 (F-gas). The regulation prohibits, among other actions, venting fluorinated greenhouse gases to the atmosphere.

The F-Gas Regulation requires operators to use all measures that are technically feasible and do not entail disproportionate cost to prevent leakage of these gases, to test for leakage regularly and to recover f-gas during equipment service and maintenance and before disposing of equipment.

Refer to the full regulation for additional details.

### 10.2 Internal Access



#### WARNING

Risk of high-speed moving parts. Can cause death, injury and equipment damage.

Before opening the Liebert XDV, shut the unit off and disconnect all electrical power. Wait for the Liebert XDV's fans to stop rotating before beginning to open the unit.



#### WARNING

Risk of electrical shock. May cause death or injury.

Disconnect all power before working within.

- Turn off the main switch (in the center of the fan tray).
- Remove both power cords from the electrical supply outlets or from the receptacles on the back of the Liebert XDV.



#### CAUTION

Risk of improper handling. May cause injury.

Use both hands when removing fan tray assembly. Improperly handling the assembly may cause injury during removal.

The conditions required for sensitive electronic equipment should preclude the accumulation of appreciable amounts of dust in the Liebert XDV. Most of that small amount should be found on the rear coils, near the air inlet. The rear covers and the fan tray on the front of the Liebert XDV are easily removed for maintenance. (A wiring diagram is provided on the inside of the fan tray.)

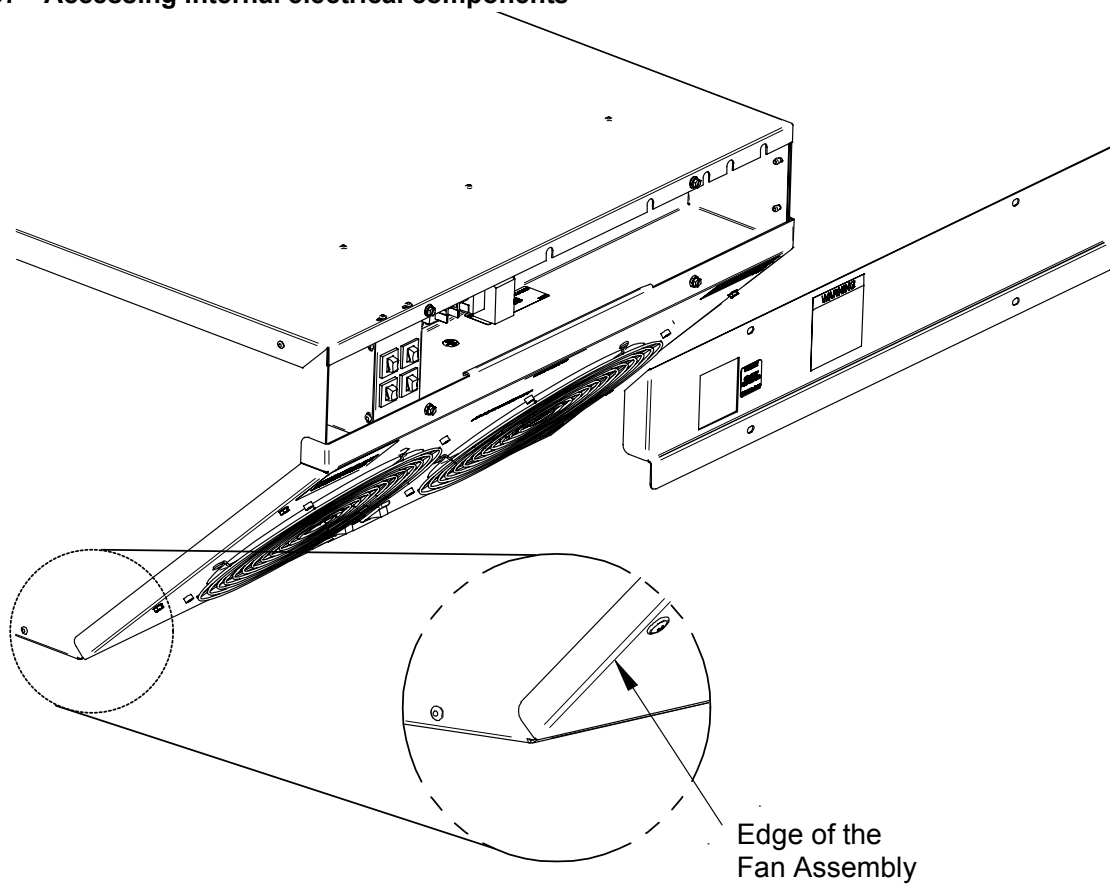
#### To remove the rear grille:

1. Loosen the six screws holding the grille on the rear of the Liebert XDV.
2. Remove the grille and lay it aside for reinstallation.

### 10.2.1 Accessing Internal Electrical Components

1. Disconnect all power inputs.
2. Remove five screws to remove the front electrical panel cover. See **Figure 37** and 12 of 13
3. Lift off the panel.

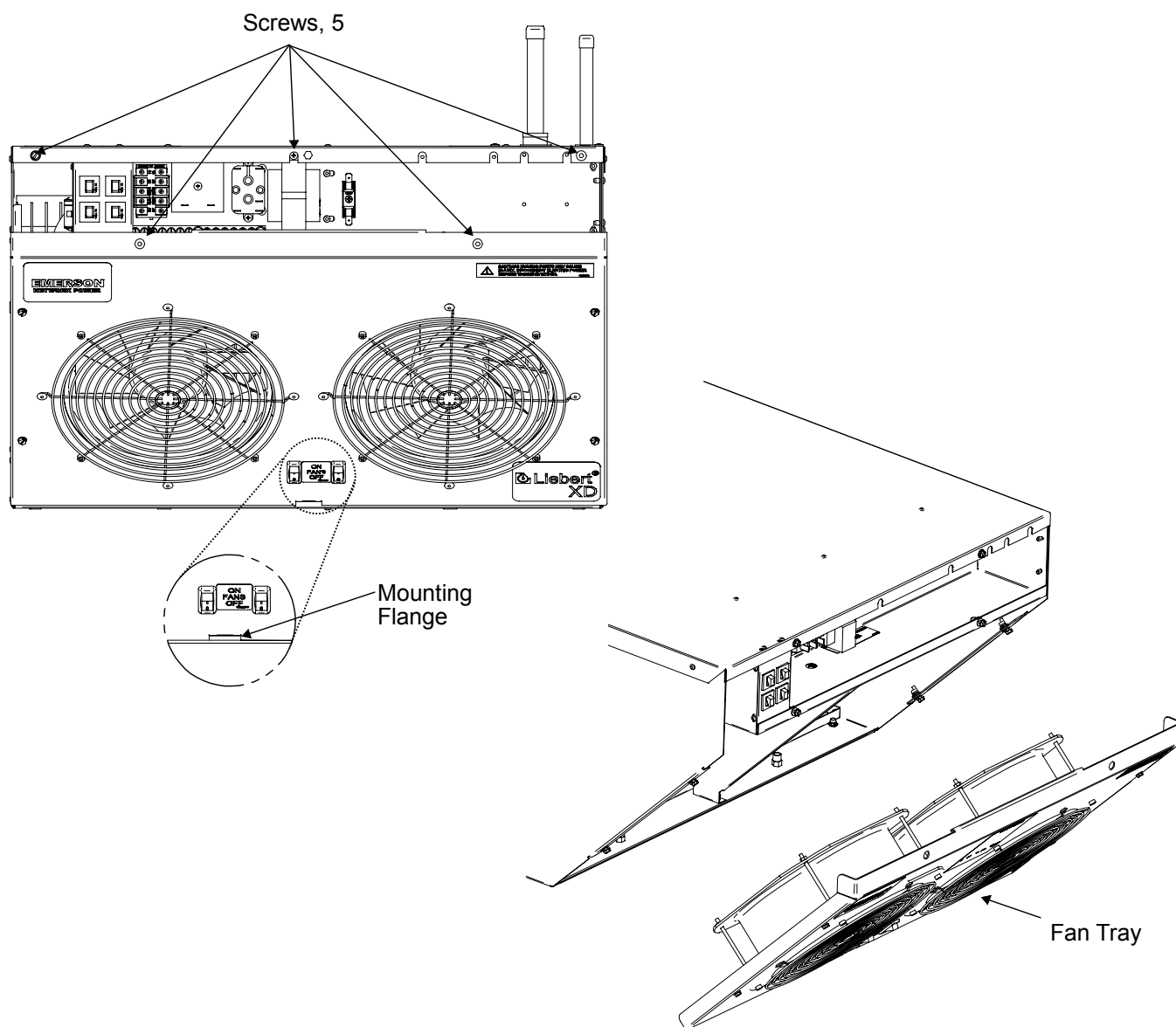
**Figure 37** Accessing internal electrical components



### To remove the fan tray:

1. Remove the front electrical panel cover as described in **10.2.1 - Accessing Internal Electrical Components**.
2. Disconnect the 12-pin connector. Take care not to stretch or stress the electrical wires to the fans.
3. Remove the four screws holding the fan tray on the Liebert XDV.
4. Support the fan tray when removing the last screw to keep it from falling.
5. Set the screws aside for reinsertion after maintenance is completed.
6. Then lift the fan tray up and set it on top of the Liebert XDV or on a nearby surface.

**Figure 38 Removing the fan tray**



### To reattach the fan tray:

1. Clean the fan tray to prevent debris from being blown into the computer cabinet.
2. Reconnect the 12-pin connector.
3. Lift the fan tray and fit it against the base of the Liebert XDV housing (see **Figure 38**).
4. Holding the fan tray against the Liebert XDV housing, insert the screws extracted when removing the fan tray.
5. Tighten the screws securely.
6. Reconnect power to the Liebert XDV.

## 11.0 SPECIFICATIONS

**Table 5 Liebert XDV10 specifications**

Models	XDV10BK--*; XDV10DK--* XDV10BKP-*; XDV10DKP-* XDV10BK-E*; XDV10DK-E* XDV10BKPE*; XDV10DKPE* XDV10BKR-*; XDV10BKRE* XDV10DKR-*; XDV10DKRE*	XDV10BT--*; XDV10DT--* XDV10BTP-*; XDV10DTP-* XDV10BT-E*; XDV10DT-E* XDV10BTPE*; XDV10DTPE* XDV10BTR-*; XDV10BTRE* XDV10DTR-*; XDV10DTRE*	XDV10BS--*; XDV10DS--* XDV10BSP-*; XDV10DSP-* XDV10BS-E*; XDV10DS-E* XDV10BSPE*; XDV10DSPE* XDV10BSR-*; XDV10BSRE* XDV10DSR-*; XDV10DSRE*	
	60 Hz	60 Hz	50 Hz	50 Hz
<b>Cooling Capacity</b>	Nominal (98°F [37°C] EAT): 10kW / 2.8 Tons Maximum (106°F [41°C] EAT): 11.8kW/3.4 Tons		Nominal (98°F [37°C] EAT): 8kW / 2.3 Tons Maximum (116°F [47°C] EAT): 11.8kW/3.4 Tons	
<b>Conditions</b>	Capacity Rating is @ 55°F (13°C) Entering Fluid Temperature and 50°F (10°C) or lower dew point, rear air inlet.			
<b>Electrical Requirements</b>				
Input	120V model: 1ph-60 Hz	230V model: 1ph-60 Hz	230V model: 1ph-50 Hz	
Input power connections	2 power connections, each model			
Full Load Amps	120V model: 2.0A	230V model: 1.0A		
Power consumption, nominal, watts	180	190	190	190
<b>Dimensions, inches (mm)</b>				
Height – unit only	14 (355) not including pipe connections			
Height – including hard pipe connections	18-5/8 (473)			
Height – including one-shot connections	19-5/8 (498)			
Width	22-7/8 (581)			
Depth – Top	39-1/2 (1003)			
Depth – Bottom	29-5/8 (752)			
<b>Weight, lb (kg)</b>				
Unit only	77 (35)			
Shipping weight	125 (57)			
Installed, with refrigerant	79 (36)			
<b>Number of fans</b>	2	2	2	2
<b>Airflow, Nominal, ft<sup>3</sup>/ min (m<sup>3</sup>/ hr)</b>	1000 (1699) with rear inlet. Bottom inlet airflow may be less, depending on restrictions inside cabinet		833 (1415) with rear inlet. Bottom inlet airflow may be less, depending on restrictions inside cabinet	
<b>Audible noise</b>	78 dBA sound power		73 dBA sound power	
<b>Pipe Connections (without Liebert Flex Pipe)</b>				
Refrigerant supply from Liebert XDP/ XDC	1/2" OD, Cu, (optional 1/2" threaded coupler flex piping)			
Refrigerant return to Liebert XDP/ XDC	5/8" OD, Cu, (optional 3/4" threaded coupler flex piping)			
<b>Serviceable Parts</b>	Fans and electrical components			
<b>Cabinet Exterior Finish</b>	Black, matte finish, heat-fused powder coat			
<b>Options</b>				
Condensate sensing (factory-installed)	Dry contact outgoing signal			
Pre-Charged Refrigerant	R-134a Refrigerant, one-shot connections			
<b>Agency</b>				
Approvals	CSA 60Hz	CSA 50Hz	CE 50Hz	

\* = Revision level of unit

**Table 6 Liebert XDV8 specifications**

<b>Models</b>	XDV8BK--*; XDV8DK--* XDV8BKP-*; XDV8DKP-* XDV8BK-E*; XDV8DK-E* XDV8BKPE*; XDV8DKPE* XDV8BKR-*; XDV8BKRE* XDV8DKR-*; XDV8DKRE*	XDV8BT--*; XDV8DT--* XDV8BTP-*; XDV8DTP-* XDV8BT-E*; XDV8DT-E* XDV8BTPE*; XDV8DTPE* XDV8BTR-*; XDV8BTRE* XDV8DTR-*; XDV8DTRE*		XDV8BS--*; XDV8DS--* XDV8BSP-*; XDV8DSP-* XDV8BS-E*; XDV8DS-E* XDV8BSPE*; XDV8DSPE* XDV8BSR-*; XDV8BSRE* XDV8DSR-*; XDV8DSRE*
	60 Hz	60 Hz	50 Hz	50 Hz
<b>Cooling Capacity</b>	Nominal (98°F [37°C] EAT): 8.8kW / 2.5 Tons Maximum (95°F [35°C] EAT): 8.8kW / 2.5 Tons		Nominal (98°F [37°C] EAT): 8kW/2.3 Tons Maximum (103°F [39°C] EAT): 8.8kW/2.5Tons	
<b>Conditions</b>	Capacity rating is @ 55°F (13°C) Entering Fluid Temperature and 50°F (10°C) or lower dew point, rear air inlet.			
<b>Electrical Requirements</b>				
Input	120V model: 1ph-60 Hz	230V model: 1ph-60 Hz	230V model: 1ph-50 Hz	
Input power connections	2 power connections, each model			
Full Load Amps	120V model: 2.0A	230V model: 1.0A		
Power consumption, nominal, watts	180	190	190	190
<b>Dimensions, inches (mm)</b>				
Height – unit only	14 (355) not including pipe connections			
Height – including pipe connections	18-5/8 (473)			
Width	22-7/8 (581)			
Depth – Top	39-1/2 (1003)			
Depth – Bottom	29-5/8 (752)			
<b>Weight, lb (kg)</b>				
Unit only	77 (35)			
Shipping weight	125 (57)			
Installed, with refrigerant	79 (36)			
<b>Number of Fans</b>	2	2	2	2
<b>Airflow, Nominal, ft<sup>3</sup>/ min (m<sup>3</sup>/ hr)</b>	1000 (1699) with rear inlet. Bottom inlet airflow may be less, depending on restrictions inside cabinet		833 (1415) with rear inlet. Bottom inlet airflow may be less, depending on restrictions inside cabinet	
<b>Audible noise</b>	78 dBa sound power		73 dBa sound power	
<b>Pipe Connections (without Liebert Flex Pipe)</b>				
Refrigerant Supply from Liebert XDP/Liebert XDC	1/2" OD Cu, (optional 1/2" threaded coupler flex piping)			
Refrigerant Return to Liebert XDP/Liebert XDC	5/8" OD Cu, (optional 3/4" threaded coupler flex piping)			
<b>Serviceable Parts</b>	Fans and electrical components			
<b>Cabinet Exterior Finish</b>	Black, matte finish, heat-fused powder coat			
<b>Options</b>				
Condensate sensing (factory-installed)	Dry contact outgoing signal			
Pre-Charged	R-134a Refrigerant, one-shot connections			
<b>Agency</b>				
Approvals	CSA 60Hz		CSA 50Hz	CE 50Hz

\* = Revision level of unit

**Table 7 Liebert XD Liebert Flex Pipe assemblies, supply and return**

Description	Liebert P/N Straight Connection Assembly	Liebert P/N 90-Degree Connection Assembly	Length ft (m)	Minimum Bend Radius inches (mm)	
				Supply	Return
Liebert XD Flex Pipe Kit	186568G1	186567G1	6 (1.8)	7 (178)	8 (203)
	186568G2	186567G2	10 (3.0)		
	186568G3	186567G3	8 (2.5)		
	186568G4	186567G4	4 (1.2)		



# Ensuring The High Availability Of Mission-Critical Data And Applications.

Emerson Network Power, the global leader in enabling business-critical continuity, ensures network resiliency and adaptability through a family of technologies—including Liebert power and cooling technologies—that protect and support business-critical systems. Liebert solutions employ an adaptive architecture that responds to changes in criticality, density and capacity. Enterprises benefit from greater IT system availability, operational flexibility and reduced capital equipment and operating costs.

## Technical Support / Service Web Site

[www.liebert.com](http://www.liebert.com)

### Monitoring

800-222-5877

[monitoring@emersonnetworkpower.com](mailto:monitoring@emersonnetworkpower.com)

Outside the US: 614-841-6755

### Single-Phase UPS

800-222-5877

[upstech@emersonnetworkpower.com](mailto:upstech@emersonnetworkpower.com)

Outside the US: 614-841-6755

### Three-Phase UPS

800-543-2378

[powertech@emersonnetworkpower.com](mailto:powertech@emersonnetworkpower.com)

### Environmental Systems

800-543-2778

Outside the United States

614-888-0246

### Locations

#### United States

1050 Dearborn Drive

P.O. Box 29186

Columbus, OH 43229

#### Europe

Via Leonardo Da Vinci 8

Zona Industriale Tognana

35028 Piove Di Sacco (PD) Italy

+39 049 9719 111

Fax: +39 049 5841 257

#### Asia

7/F, Dah Sing Financial Centre

108 Gloucester Road, Wanchai

Hong Kong

852 2572220

Fax: 852 28029250

While every precaution has been taken to ensure the accuracy and completeness of this literature, Liebert Corporation assumes no responsibility and disclaims all liability for damages resulting from use of this information or for any errors or omissions.

© 2008 Liebert Corporation

All rights reserved throughout the world. Specifications subject to change without notice.

® Liebert is a registered trademark of Liebert Corporation.

All names referred to are trademarks

or registered trademarks of their respective owners.

SL-16626\_REV06\_05-08

## Emerson Network Power.

The global leader in enabling *Business-Critical Continuity*.

■ AC Power

■ Embedded Computing

■ Outside Plant

■ Racks & Integrated Cabinets

■ Connectivity

■ Embedded Power

■ Power Switching & Controls

■ Services

■ DC Power

■ Monitoring

■ Precision Cooling

■ Surge Protection

*Business-Critical Continuity*, Emerson Network Power and the Emerson Network Power logo are trademarks and service marks of Emerson Electric Co.

©2008 Emerson Electric Co.